

n ≈ 1450 rpm

پمپ WKL4, WKL 4 40

| تیپ پمپ | توان P | | آمپر A | قطر پروانه D (mm) | قطر فلنج mm | | Q | | | | | | | | | |
|--------------|--------|------|--------|-------------------|-------------|------|-------------------|-------|-------|-------|-------|-------|------|------|------|--|
| | KW | HP | | | مکش | رانس | آبدھی | | | | | | | | | |
| | | | | | | | m ³ /h | 4 | 6 | 7 | 8 | 9 | 10 | 11 | 12 | |
| | | | | | | l/s | 1.11 | 1.67 | 1.95 | 2.22 | 2.5 | 2.78 | 3 | 3.34 | | |
| WKL4 40.1 D | 0.37 | 0.5 | 1 | 155 | | | | 8.6 | 8.1 | 7.7 | 7 | 6.2 | 5.3 | * | * | |
| WKL4 40.1 C | 0.55 | 0.75 | 1 | 160 | | | | 9.2 | 8.8 | 8.4 | 7.8 | 7 | 6.2 | 5.3 | * | |
| WKL4 40.1 B | 0.55 | 0.75 | 1 | 165 | | | | 9.8 | 9.5 | 9.2 | 8.7 | 8 | 7.2 | 6.2 | * | |
| WKL4 40.1 A | 0.55 | 0.75 | 1 | 170 | | | | 10.5 | 10.2 | 9.9 | 9.4 | 8.8 | 8.1 | 7.2 | 6.1 | |
| WKL4 40.2 D | 1.1 | 1.5 | 3 | 155 | | | | 17.4 | 16.3 | 15.3 | 14 | 12.3 | 10.5 | * | * | |
| WKL4 40.2 C | 1.1 | 1.5 | 3 | 160 | | | | 18.6 | 17.6 | 16.8 | 15.7 | 14.3 | 12.6 | 10.6 | * | |
| WKL4 40.2 B | 1.1 | 1.5 | 3 | 165 | | | | 19.8 | 19 | 18.3 | 17.2 | 16 | 14.4 | 12.5 | * | |
| WKL4 40.2 A | 1.1 | 1.5 | 3 | 170 | | | | 21 | 20.4 | 19.8 | 18.8 | 17.6 | 16.2 | 14.6 | 12.6 | |
| WKL4 40.3 D | 1.5 | 2 | 4 | 155 | | | | 25.8 | 24.5 | 23.2 | 21.2 | 18.8 | 16 | * | * | |
| WKL4 40.3 C | 1.5 | 2 | 4 | 160 | | | | 27.6 | 26.4 | 25.2 | 23.4 | 21.2 | 18.7 | 16 | * | |
| WKL4 40.3 B | 1.5 | 2 | 4 | 165 | | | | 29.7 | 28.5 | 27.5 | 25.8 | 23.8 | 21.5 | 19 | * | |
| WKL4 40.3 A | 2.2 | 3 | 5 | 170 | | | | 31.6 | 30.6 | 29.7 | 28.2 | 26.4 | 24.3 | 22 | 19 | |
| WKL4 40.4 D | 2.2 | 3 | 5 | 155 | | | | 34.5 | 32.8 | 31 | 28.4 | 25.2 | 21.8 | * | * | |
| WKL4 40.4 C | 2.2 | 3 | 5 | 160 | | | | 36.8 | 35.2 | 33.6 | 31.3 | 28.3 | 25 | 21.5 | * | |
| WKL4 40.4 B | 2.2 | 3 | 5 | 165 | | | | 39.4 | 38 | 36.5 | 34.4 | 31.8 | 28.8 | 25 | * | |
| WKL4 40.4 A | 2.2 | 3 | 5 | 170 | | | | 42 | 40.8 | 39.6 | 37.6 | 35.2 | 32.4 | 29.2 | 25.2 | |
| WKL4 40.5 D | 2.2 | 3 | 5 | 155 | | | | 43 | 41 | 38.8 | 35.5 | 31.5 | 27 | * | * | |
| WKL4 40.5 C | 2.2 | 3 | 5 | 160 | | | | 46.2 | 44 | 42 | 39 | 35.4 | 31.4 | 27 | * | |
| WKL4 40.5 B | 2.2 | 3 | 5 | 165 | | | | 49.5 | 50 | 45.6 | 43 | 39.8 | 36 | 31.5 | * | |
| WKL4 40.5 A | 3 | 4 | 7 | 170 | | | | 53 | 51.2 | 49.5 | 47 | 44 | 40.5 | 36.5 | 31.5 | |
| WKL4 40.6 D | 3 | 4 | 7 | 160 | | | | 52 | 49 | 46 | 42 | 37 | 31.5 | * | * | |
| WKL4 40.6 C | 3 | 4 | 7 | 160 | | | | 55.6 | 52.8 | 50.3 | 46.8 | 42 | 37.2 | 31.8 | * | |
| WKL4 40.6 B | 3 | 4 | 7 | 165 | | | | 59.4 | 57 | 54.8 | 51.6 | 47.6 | 43 | 37.4 | | |
| WKL4 40.6 A | 3 | 4 | 7 | 170 | 50 | 40 | H (m) | 63 | 61.2 | 59.4 | 56.4 | 52.8 | 48.6 | 43.8 | 37.8 | |
| WKL4 40.7 D | 3 | 4 | 7 | 155 | | | | 60.5 | 57.2 | 54 | 49.3 | 43.7 | 37.5 | * | * | |
| WKL4 40.7 C | 3 | 4 | 7 | 160 | | | | 64.5 | 61.5 | 58.7 | 54.5 | 49 | 43.3 | 37 | * | |
| WKL4 40.7 B | 4 | 5.5 | 9 | 165 | | | | 69.3 | 66.5 | 64 | 60.2 | 55.4 | 50 | 44 | * | |
| WKL4 40.7 A | 4 | 5.5 | 9 | 170 | | | | 73.5 | 71.4 | 69.3 | 65.8 | 61.6 | 56.7 | 51 | 44 | |
| WKL4 40.8 D | 4 | 5.5 | 9 | 155 | | | | 69.2 | 65.4 | 61.6 | 56 | 49.2 | 42 | * | * | |
| WKL4 40.8 C | 4 | 5.5 | 9 | 160 | | | | 74.3 | 70.4 | 67.2 | 62.4 | 56.5 | 49.6 | 42.4 | * | |
| WKL4 40.8 B | 4 | 5.5 | 9 | 165 | | | | 79.2 | 76 | 72.8 | 68.8 | 63.8 | 57.4 | 50 | * | |
| WKL4 40.8 A | 4 | 5.5 | 9 | 170 | | | | 83.8 | 81.5 | 79 | 75.2 | 70.4 | 64.8 | 58.4 | 50.4 | |
| WKL4 40.9 D | 4 | 5.5 | 9 | 155 | | | | 78 | 73.6 | 69.4 | 63.6 | 56 | 47.2 | * | * | |
| WKL4 40.9 C | 4 | 5.5 | 9 | 160 | | | | 83.2 | 79 | 75.4 | 70.2 | 63.4 | 55.8 | 48 | * | |
| WKL4 40.9 B | 4 | 5.5 | 9 | 165 | | | | 89 | 85.4 | 82 | 77.3 | 71.2 | 64.5 | 56 | * | |
| WKL4 40.9 A | 5.5 | 7.5 | 12 | 170 | | | | 94.5 | 91.8 | 89 | 84.6 | 79.2 | 73 | 65.7 | 56.7 | |
| WKL4 40.10 D | 4 | 5.5 | 9 | 155 | | | | 86 | 81.8 | 77 | 70.5 | 62.5 | 53.5 | * | * | |
| WKL4 40.10 C | 5.5 | 7.5 | 12 | 160 | | | | 92 | 88 | 84 | 78 | 70.5 | 62.4 | 53 | * | |
| WKL4 40.10 B | 5.5 | 7.5 | 12 | 165 | | | | 99 | 95 | 91.5 | 86 | 79 | 71.5 | 62.5 | * | |
| WKL4 40.10 A | 5.5 | 7.5 | 12 | 170 | | | | 105 | 102 | 99 | 94.5 | 88.5 | 81 | 73 | 63 | |
| WKL4 40.11 D | 4 | 5.5 | 9 | 155 | | | | 95 | 89.8 | 84.5 | 77 | 68 | 58 | * | * | |
| WKL4 40.11 C | 5.5 | 7.5 | 12 | 160 | | | | 102 | 96.8 | 92.2 | 85.8 | 77.4 | 68.2 | 58.3 | * | |
| WKL4 40.11 B | 5.5 | 7.5 | 12 | 165 | | | | 109 | 104.7 | 101 | 95 | 87.4 | 78.8 | 69 | * | |
| WKL4 40.11 A | 7.5 | 10 | 16 | 170 | | | | 115.5 | 112.2 | 109 | 103.4 | 96.8 | 89 | 80.3 | 69.3 | |
| WKL4 40.12 D | 5.5 | 7.5 | 12 | 155 | | | | 103.8 | 98.3 | 92.5 | 84 | 74 | 63 | * | * | |
| WKL4 40.12 C | 5.5 | 7.5 | 12 | 160 | | | | 111 | 105.6 | 100.5 | 93.6 | 84 | 74.4 | 63.6 | * | |
| WKL4 40.12 B | 5.5 | 7.5 | 12 | 165 | | | | 118.8 | 114 | 109.4 | 103.2 | 95 | 86.2 | 75 | * | |
| WKL4 40.12 A | 7.5 | 10 | 16 | 170 | | | | 126 | 122.4 | 118.8 | 112.8 | 105.6 | 97.2 | 87.6 | 75.6 | |

| H | m | 4.6 | 9.2 | 13.7 | 22.8 | 32 | 41 | 50.2 | 64 | 78 | 91 | 105 | 128 |
|---|----|-----|-----|------|------|-----|-----|------|-----|-----|-----|-----|-----|
| | ft | 15 | 30 | 45 | 75 | 105 | 135 | 165 | 210 | 255 | 300 | 345 | 420 |

| Q | m ³ /h | 4 | 6 | 7 | 8 | 9 | 10 | 11 | 12 |
|---|-------------------|----|----|----|----|----|----|----|----|
| | g.p.m | 15 | 23 | 27 | 30 | 34 | 38 | 42 | 46 |

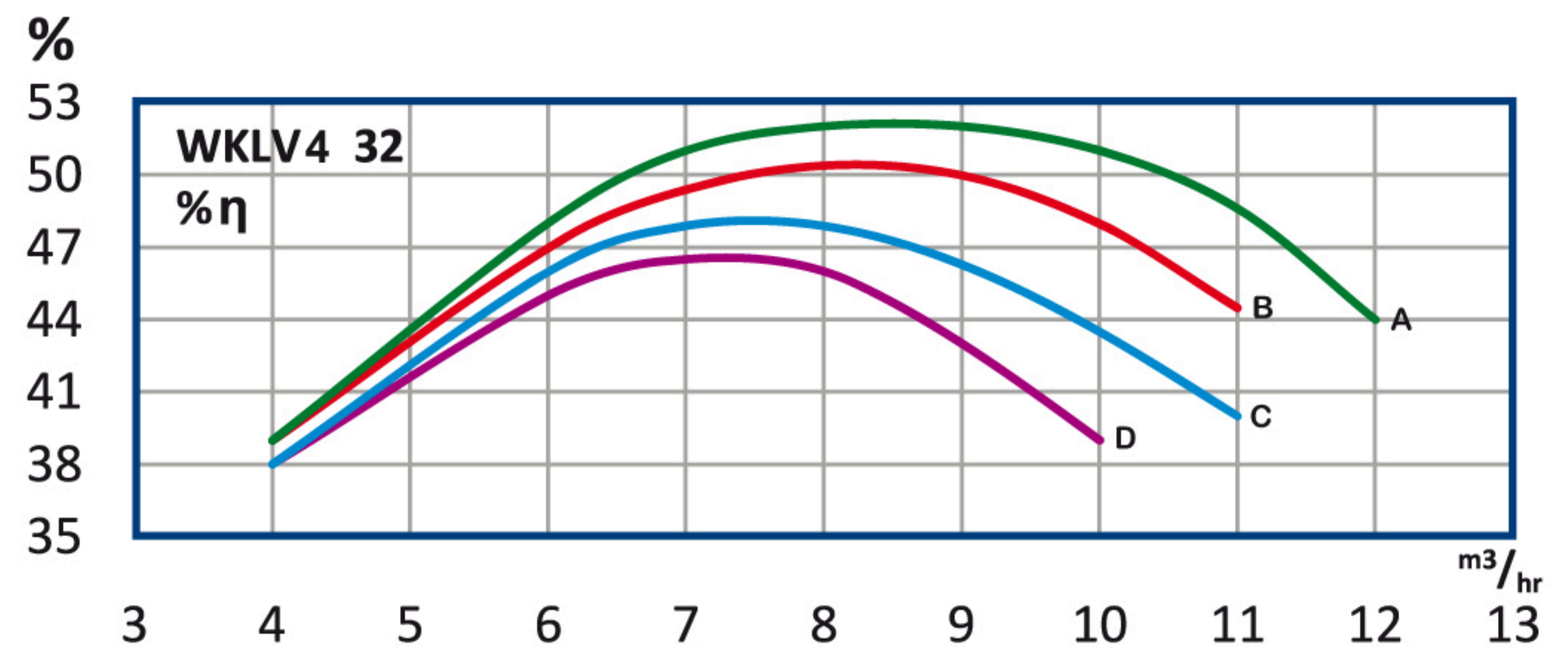
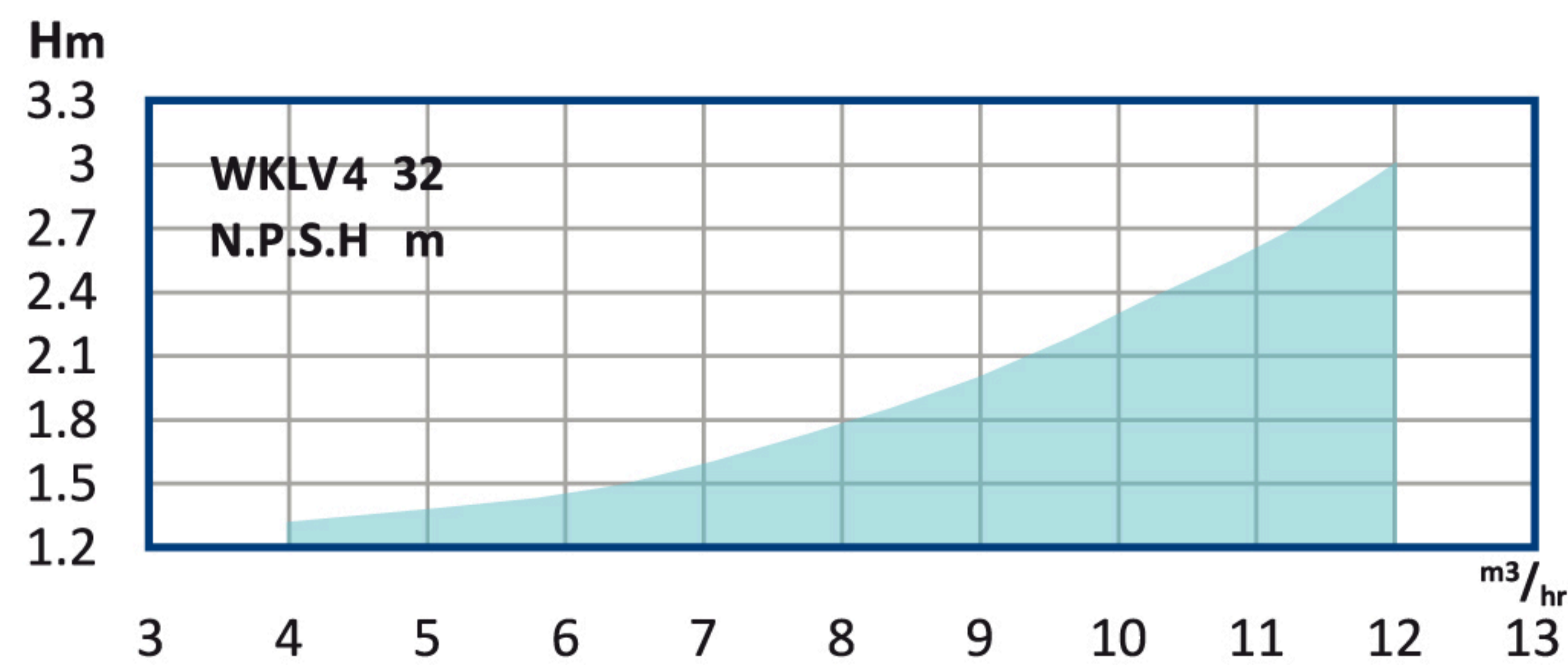
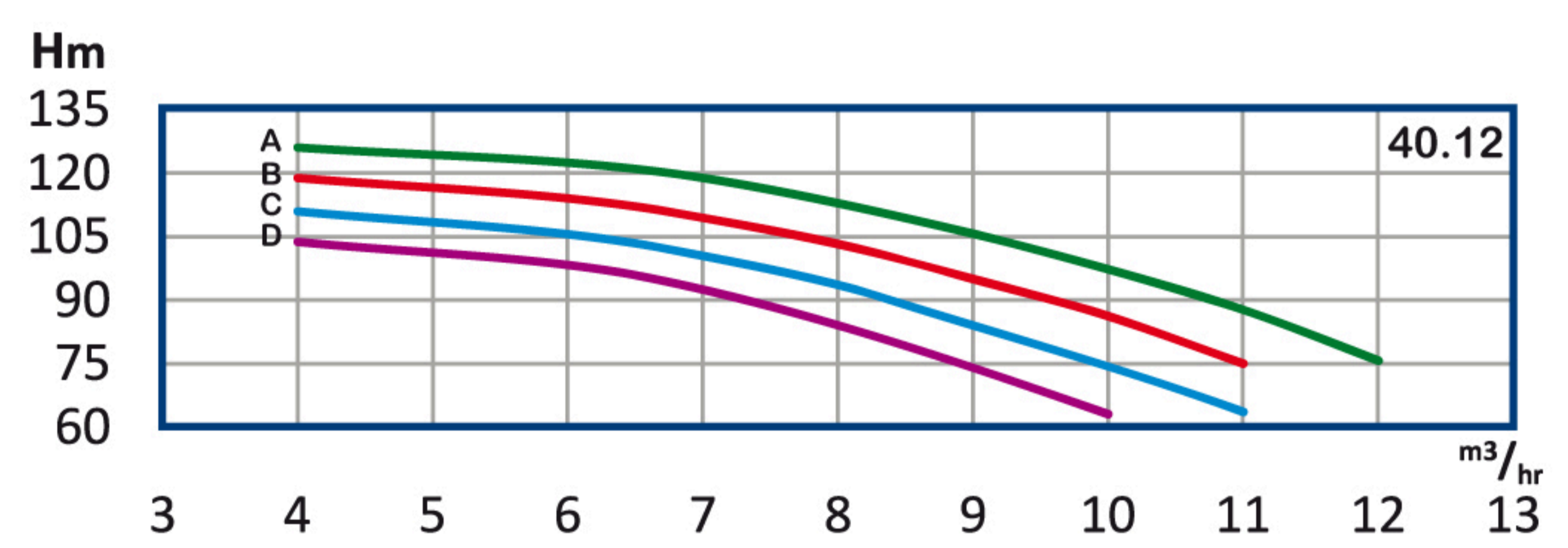
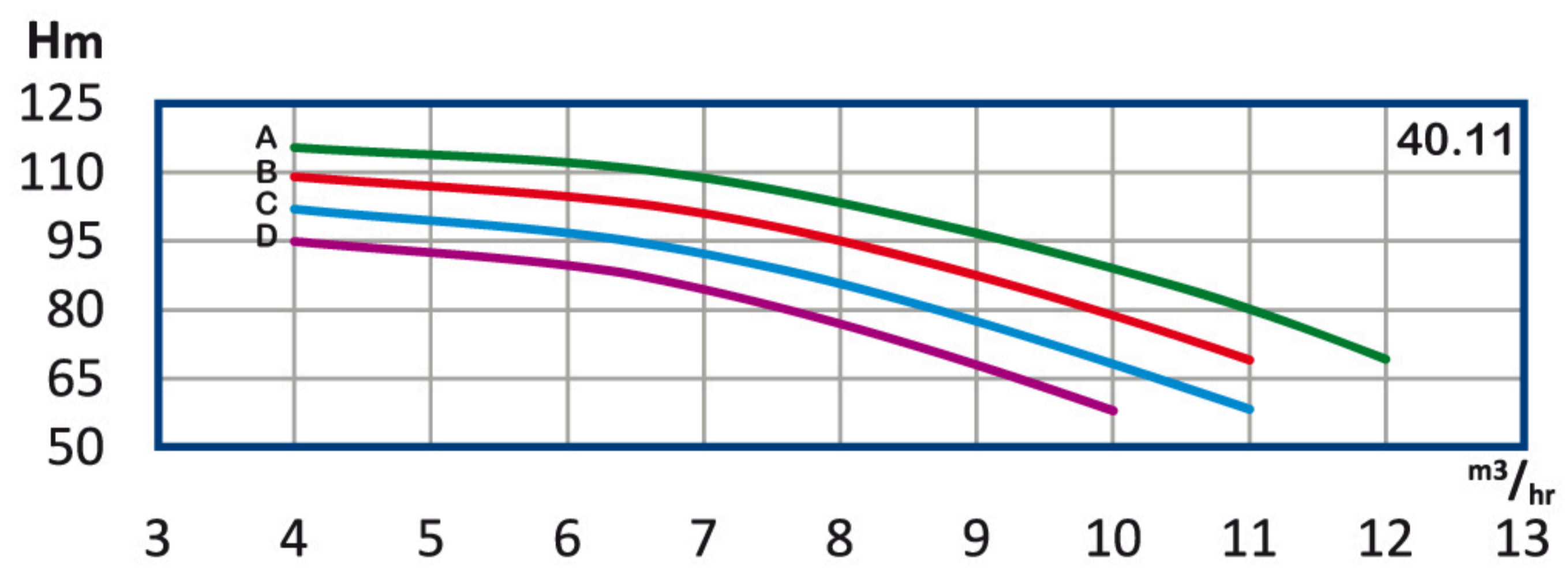
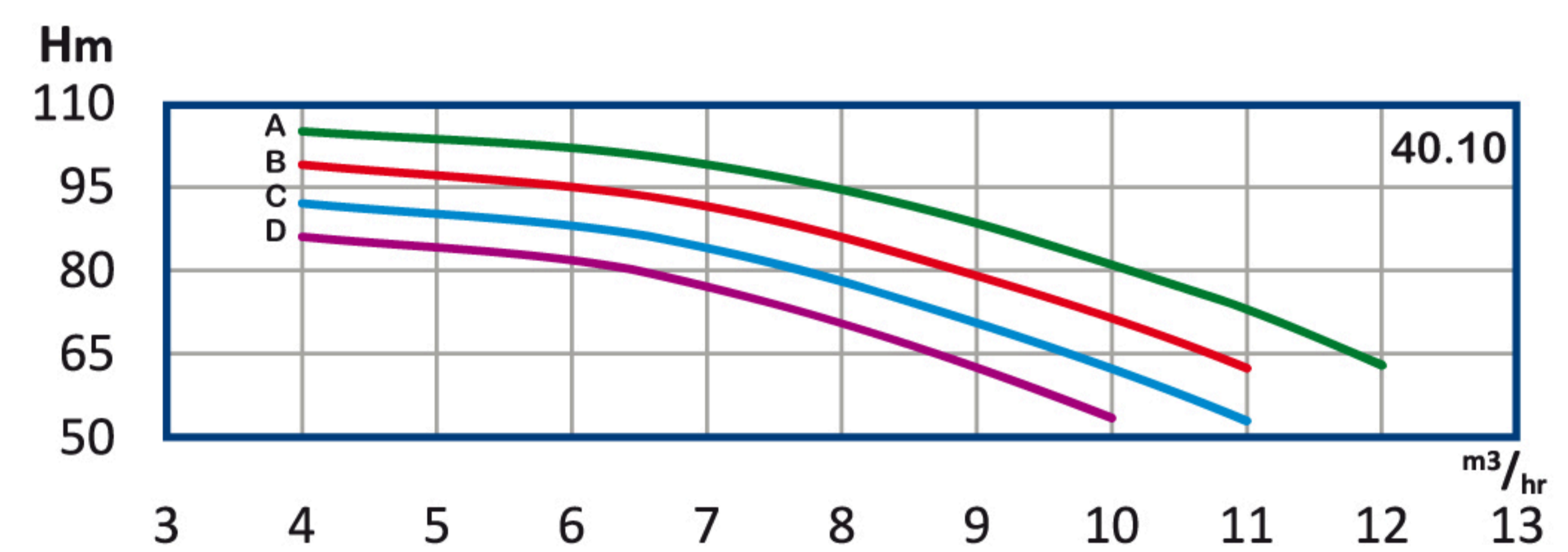
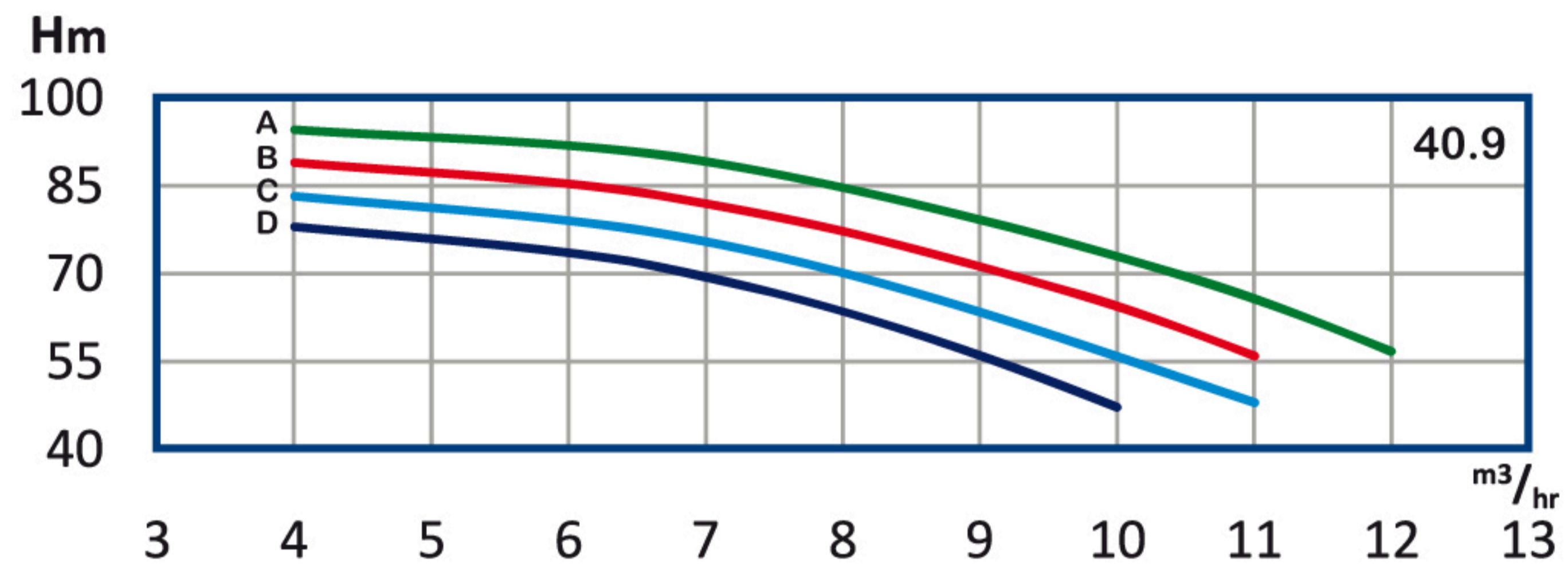
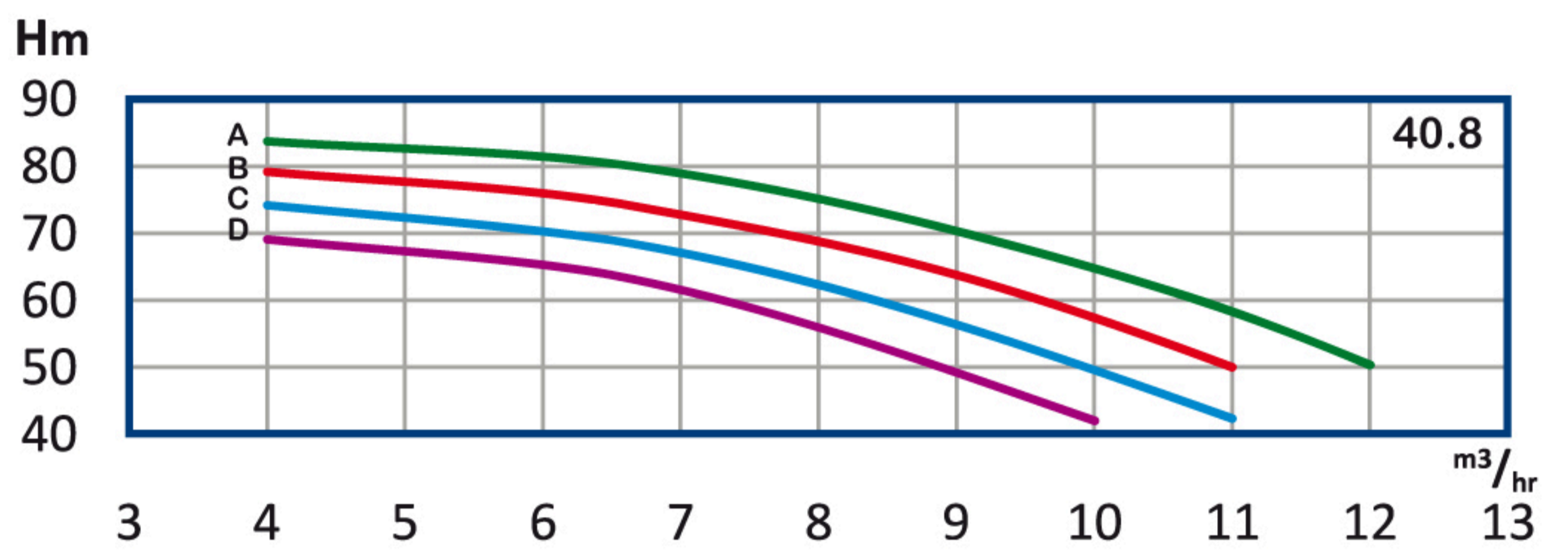
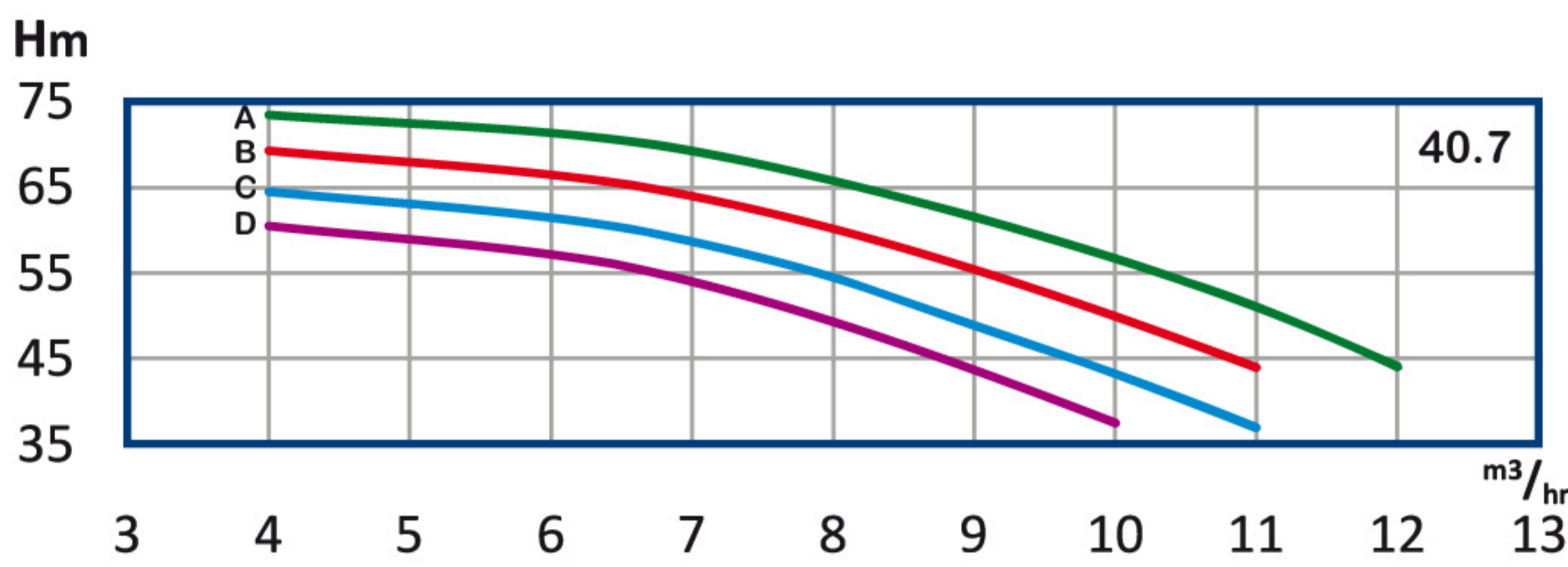
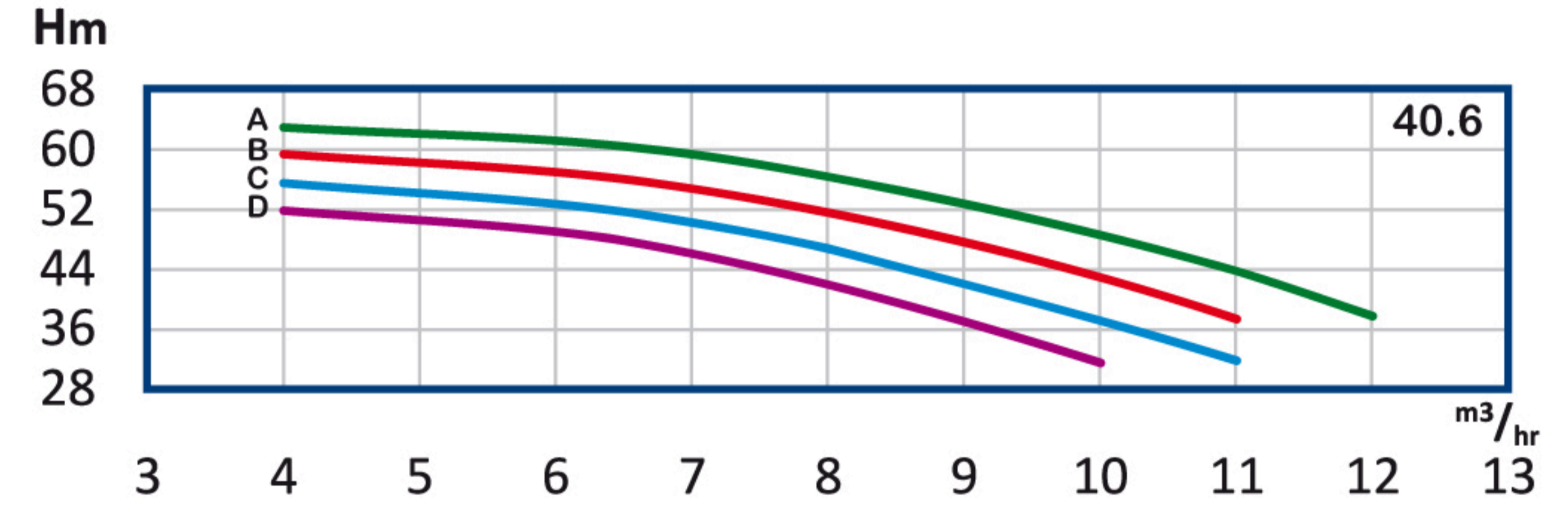
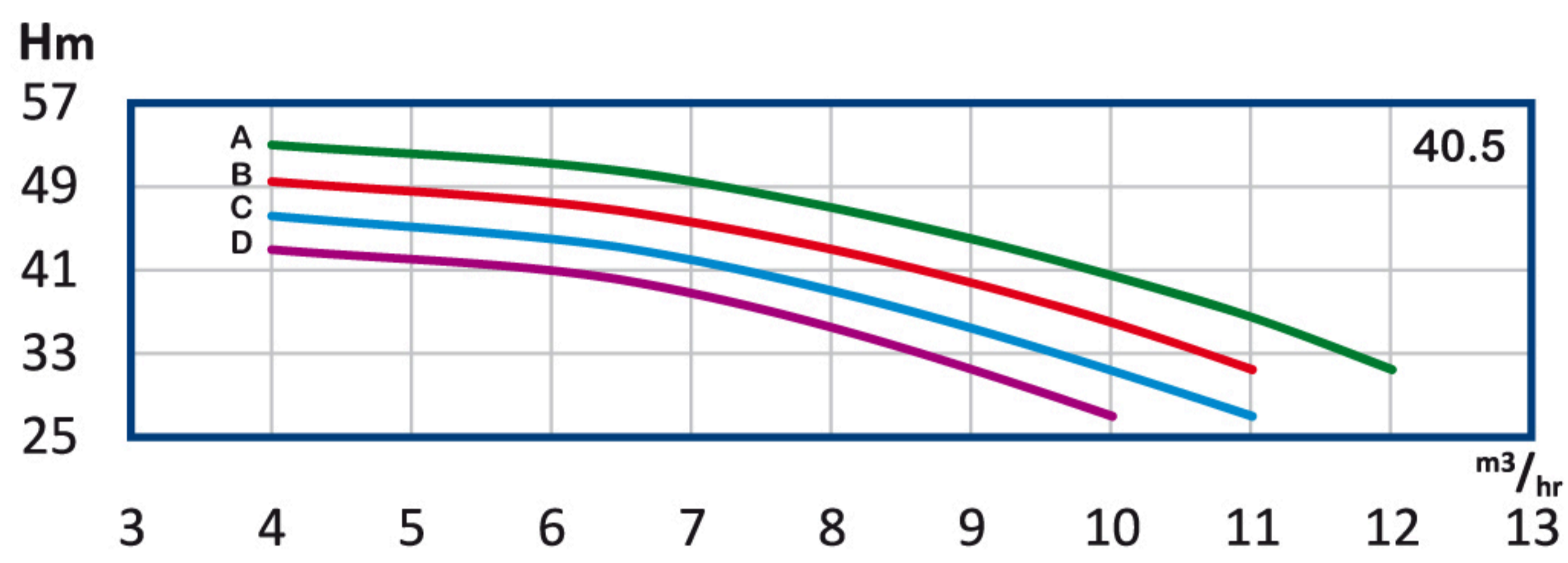
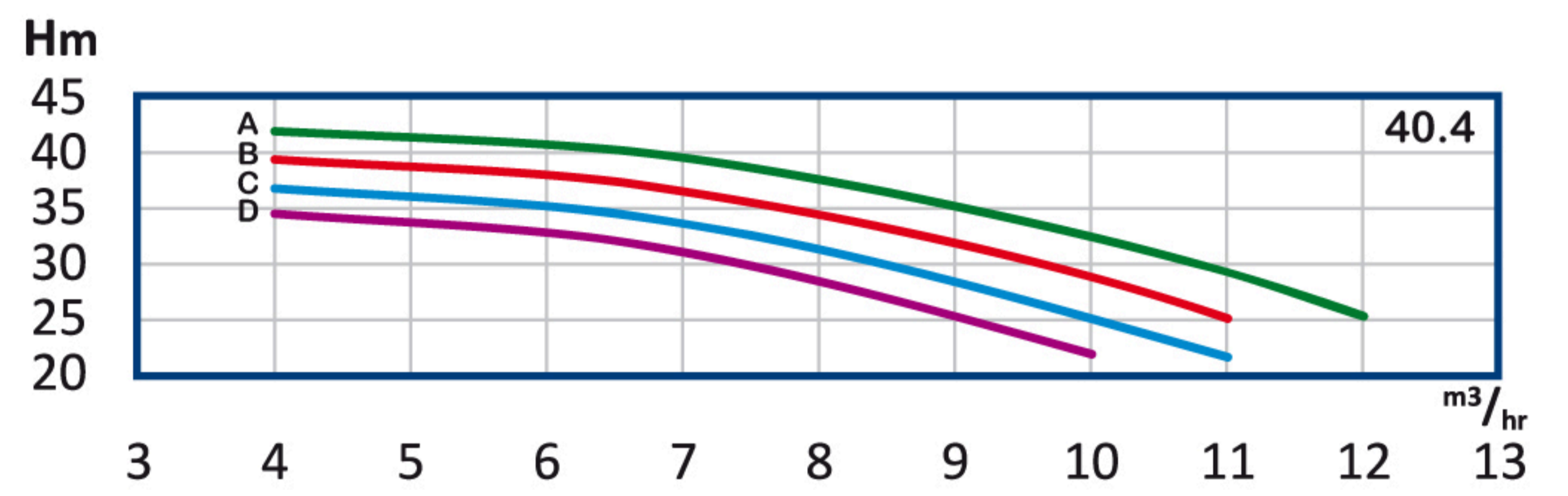
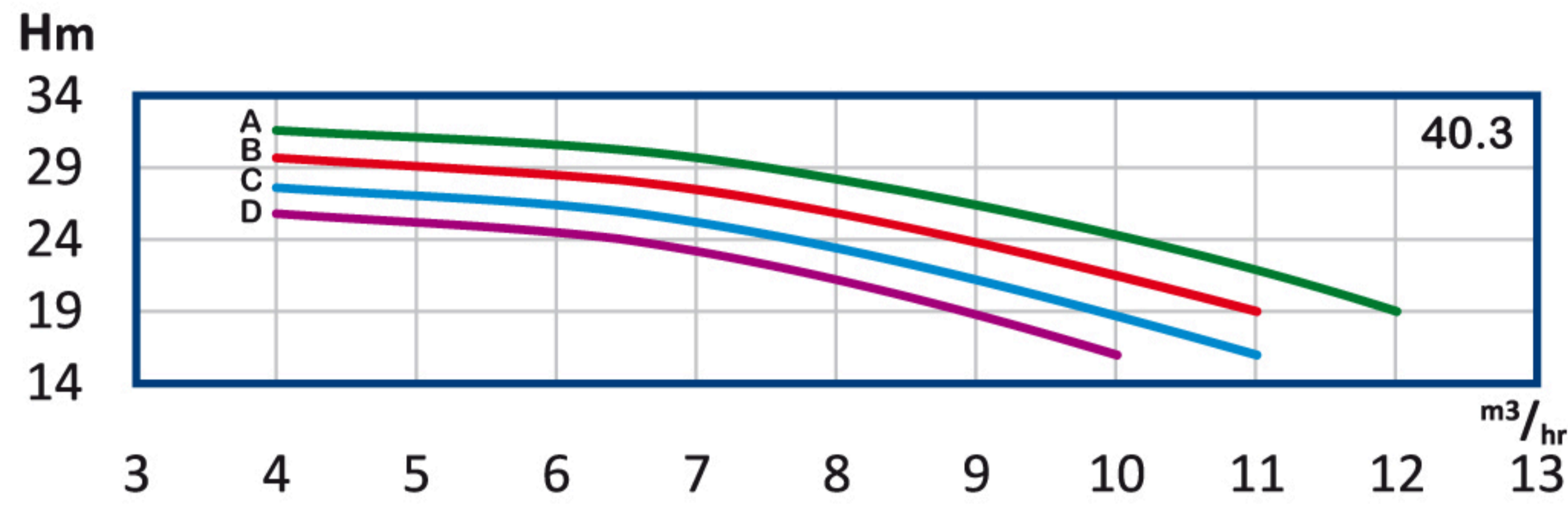
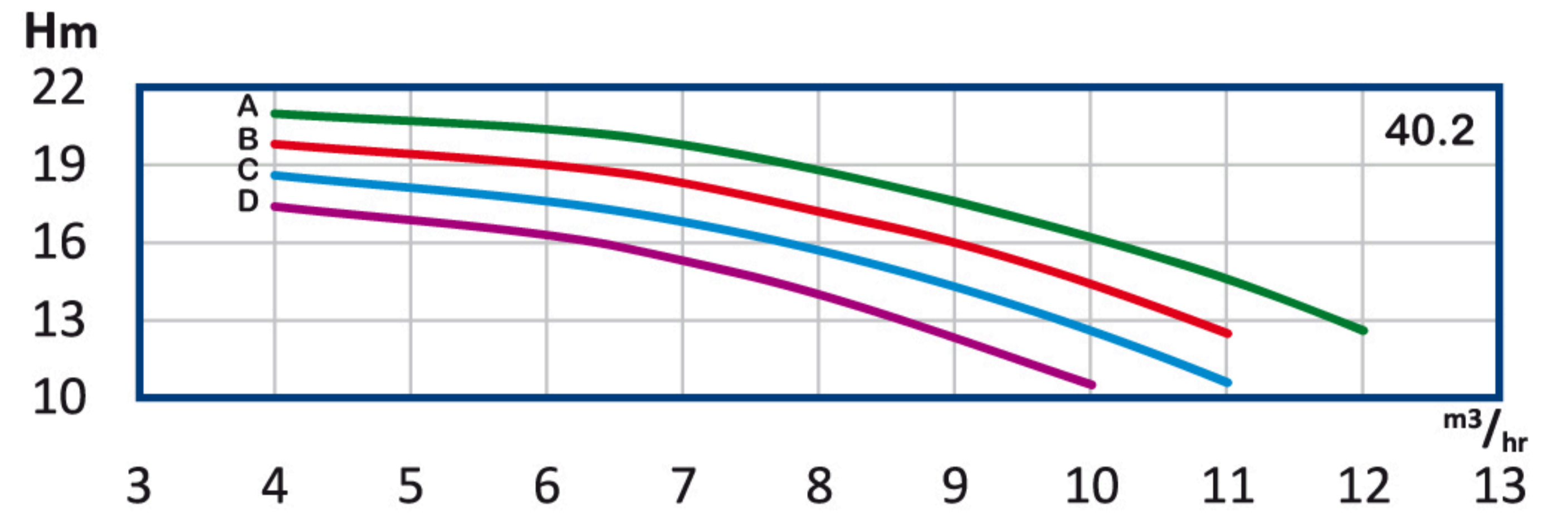
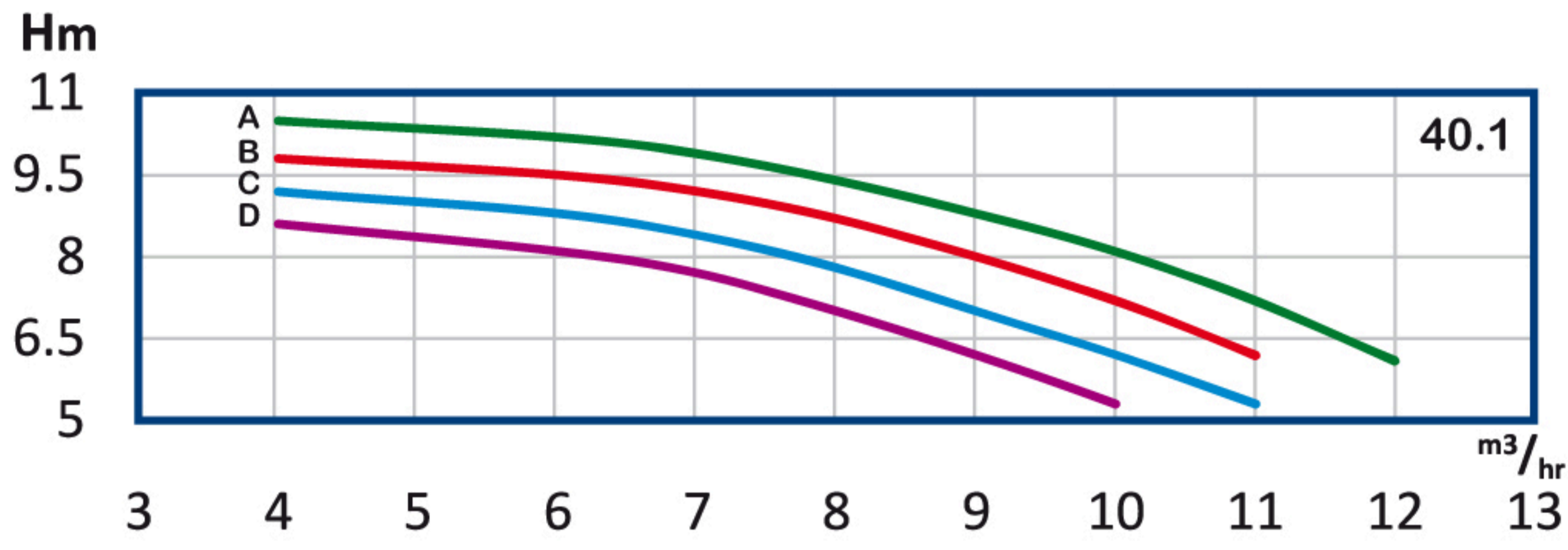

n ≈ 1450 rpm

پمپ WKL4, WKL 4 40

| تیپ پمپ | توان P | | آمپر A | قطر پروانه D (mm) | قطر فلنج mm | | Q آبدھی | | | | | | | | |
|--------------|--------|-----|--------|-------------------|-------------|------|-------------------|-------|-------|-------|-------|-------|-------|-------|-------|
| | KW | HP | | | مکش | رانس | m ³ /h | 4 | 6 | 7 | 8 | 9 | 10 | 11 | 12 |
| | | | | | | | | | | | | | | | |
| WKL4 40.13 D | 5.5 | 7.5 | 12 | 155 | 50 | 40 | H (m) | 113 | 106 | 100 | 91 | 80 | 69 | * | * |
| WKL4 40.13 C | 7.5 | 10 | 16 | 160 | | | | 121 | 114.4 | 109 | 101.4 | 91.5 | 81 | 69 | * |
| WKL4 40.13 B | 7.5 | 10 | 16 | 165 | | | | 128.7 | 123.5 | 118.5 | 111.8 | 103 | 93 | 80.6 | * |
| WKL4 40.13 A | 7.5 | 10 | 16 | 170 | | | | 136.5 | 132.2 | 128.7 | 122.2 | 114.4 | 105.3 | 94.5 | 81.5 |
| WKL4 40.14 D | 5.5 | 7.5 | 12 | 155 | | | | 121 | 114 | 107.5 | 98 | 86 | 73.5 | * | * |
| WKL4 40.14 C | 5.5 | 7.5 | 12 | 160 | | | | 130.2 | 123.2 | 117.4 | 109.2 | 98.5 | 86.8 | 74.2 | * |
| WKL4 40.14 B | 7.5 | 10 | 16 | 165 | | | | 138.6 | 133 | 127.5 | 120.4 | 111 | 100 | 86.8 | * |
| WKL4 40.14 A | 11 | 15 | 22 | 170 | | | | 147 | 142.8 | 138.6 | 131.6 | 123.2 | 113.4 | 102.2 | 88.2 |
| WKL4 40.15 D | 5.5 | 7.5 | 12 | 155 | | | | 130 | 122.5 | 115.5 | 106 | 93 | 79 | * | * |
| WKL4 40.15 C | 7.5 | 10 | 16 | 160 | | | | 139.5 | 132 | 125.7 | 117 | 105.5 | 93 | 79.5 | * |
| WKL4 40.15 B | 7.5 | 10 | 16 | 165 | | | | 148.5 | 142.5 | 137 | 129 | 119 | 107.5 | 93 | * |
| WKL4 40.15 A | 11 | 15 | 22 | 170 | | | | 157.5 | 153 | 148.5 | 141 | 132 | 121 | 109 | 94 |
| WKL4 40.16 D | 7.5 | 10 | 16 | 155 | | | | 139 | 131 | 123.5 | 112 | 98.5 | 84 | * | * |
| WKL4 40.16 C | 7.5 | 10 | 16 | 160 | | | | 148.5 | 140.8 | 134.5 | 124.8 | 113 | 100 | 85 | * |
| WKL4 40.16 B | 7.5 | 10 | 16 | 165 | | | | 158.4 | 151.5 | 146 | 137.6 | 127 | 115 | 100.5 | * |
| WKL4 40.16 A | 11 | 15 | 22 | 170 | | | | 168 | 163.2 | 158.4 | 150.4 | 140.8 | 129.6 | 116.8 | 100.8 |

| H | m | 64 | 73 | 82 | 91 | 100 | 110 | 119 | 130 | 140 | 151 | 159 | 171 |
|---|----|-----|-----|-----|-----|-----|-----|-----|-----|-----|-----|-----|-----|
| | ft | 210 | 240 | 270 | 300 | 330 | 360 | 390 | 425 | 460 | 495 | 520 | 560 |

| Q | m ³ /h | 4 | 6 | 7 | 8 | 9 | 10 | 11 | 12 |
|---|-------------------|----|----|----|----|----|----|----|----|
| | g.p.m | 15 | 23 | 27 | 30 | 34 | 38 | 42 | 46 |

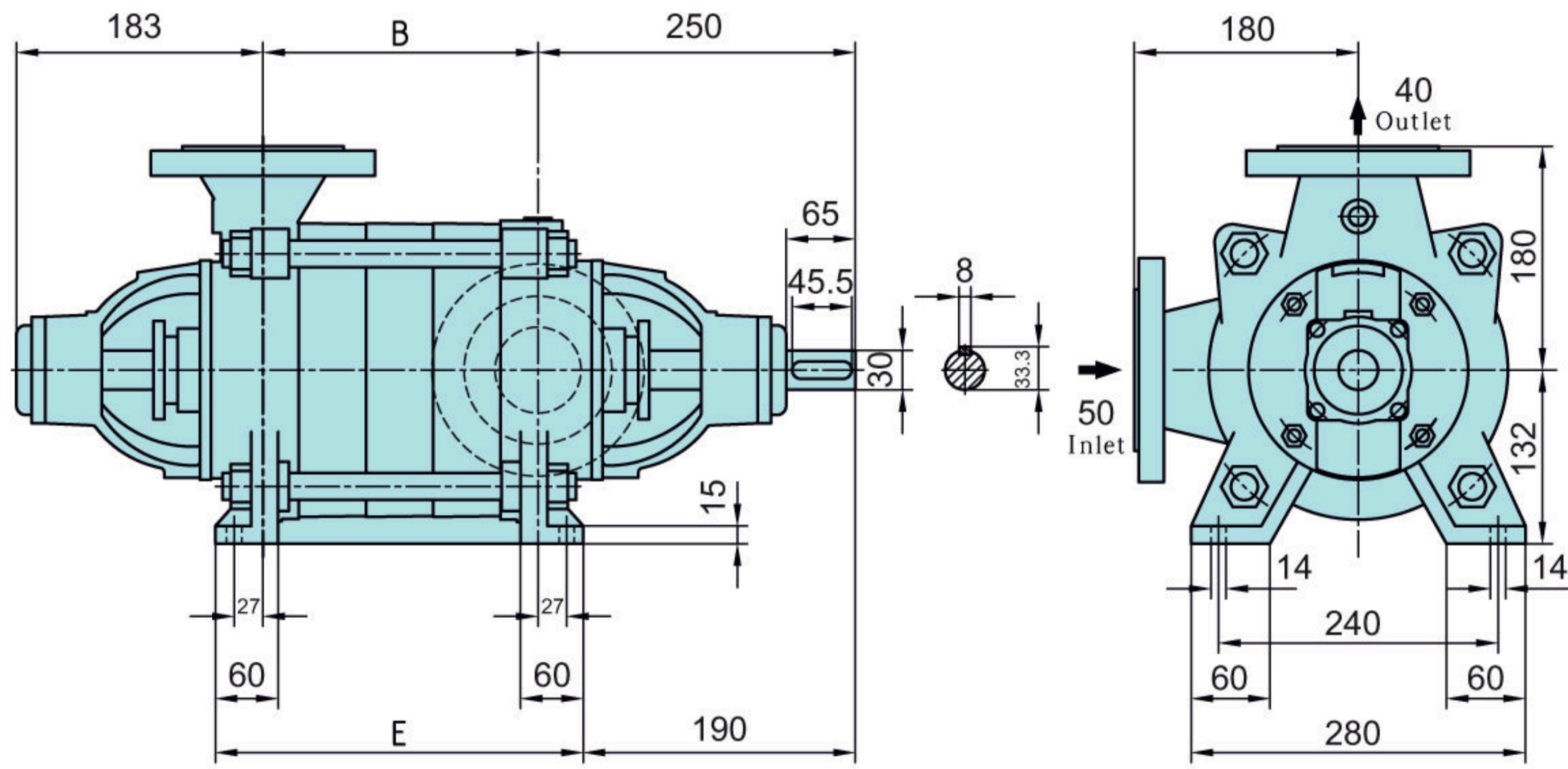
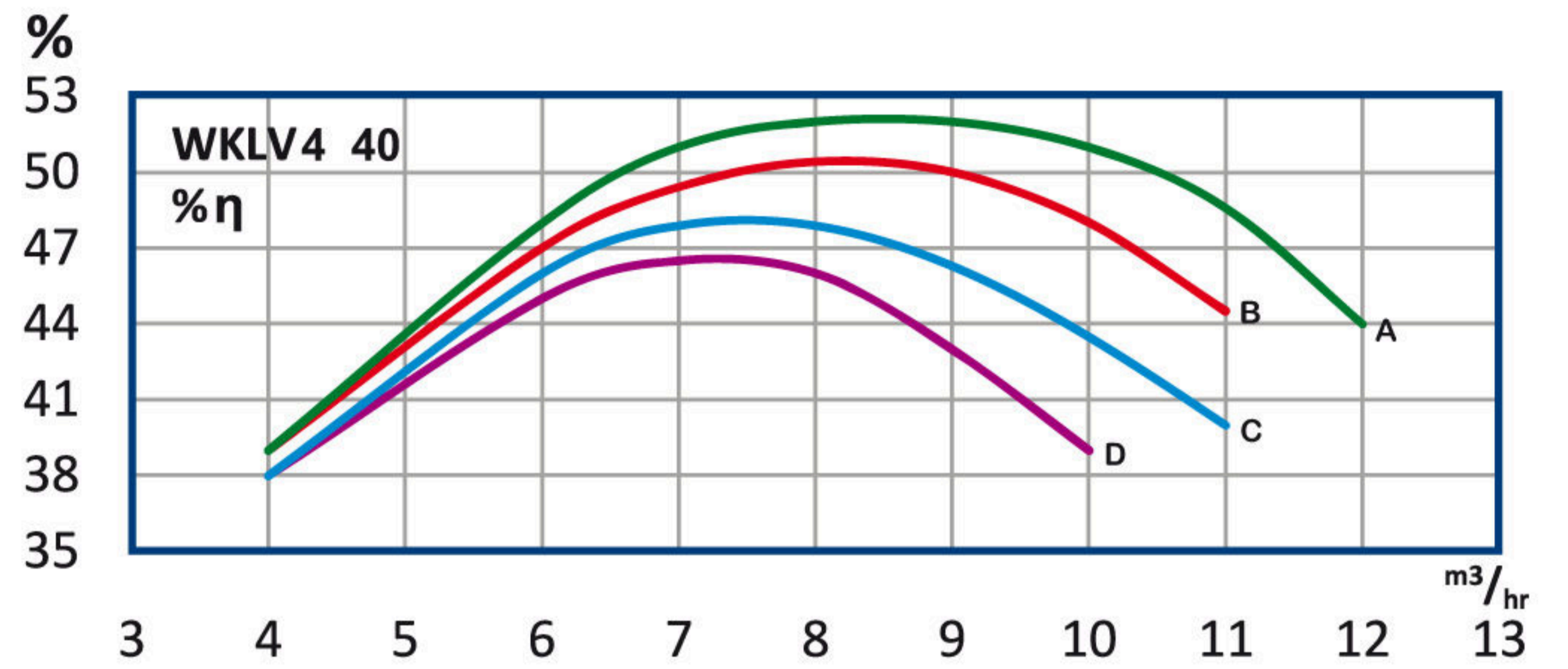
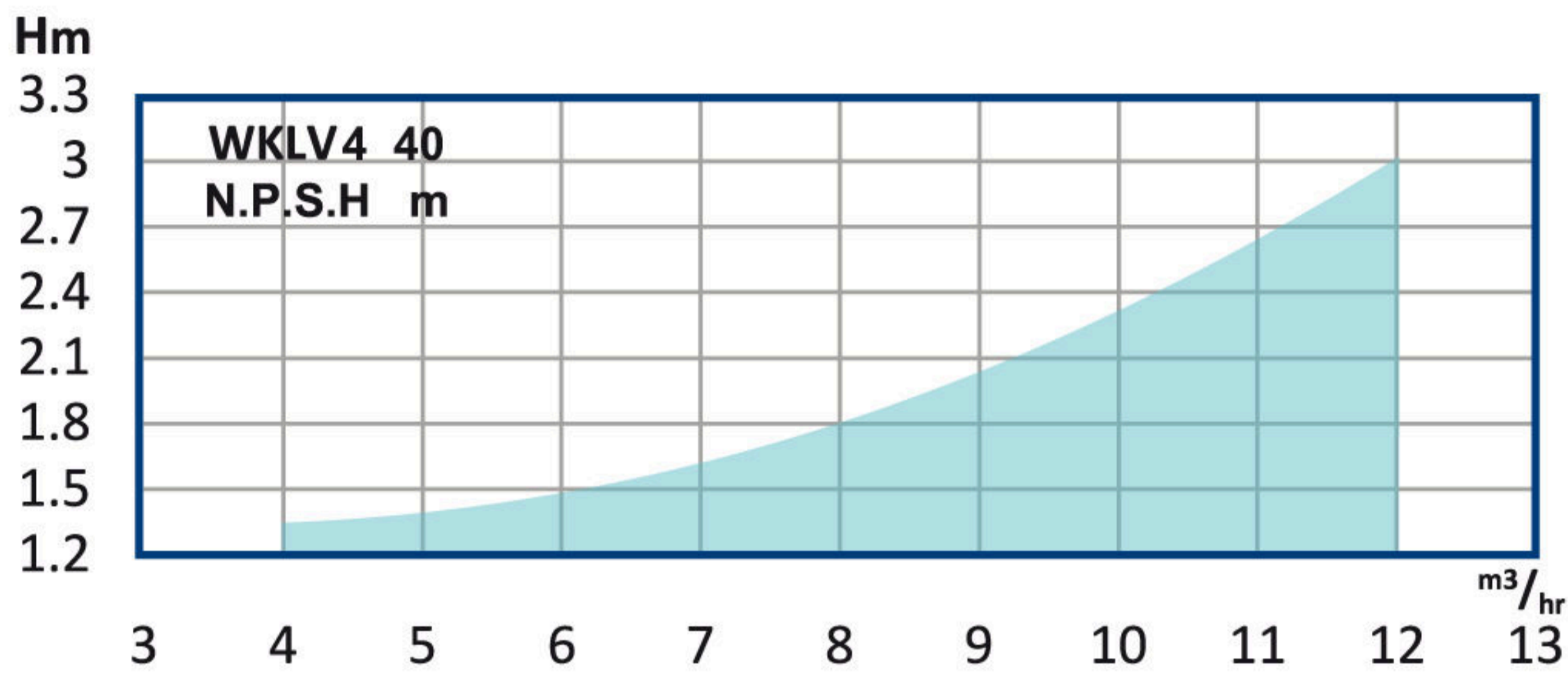
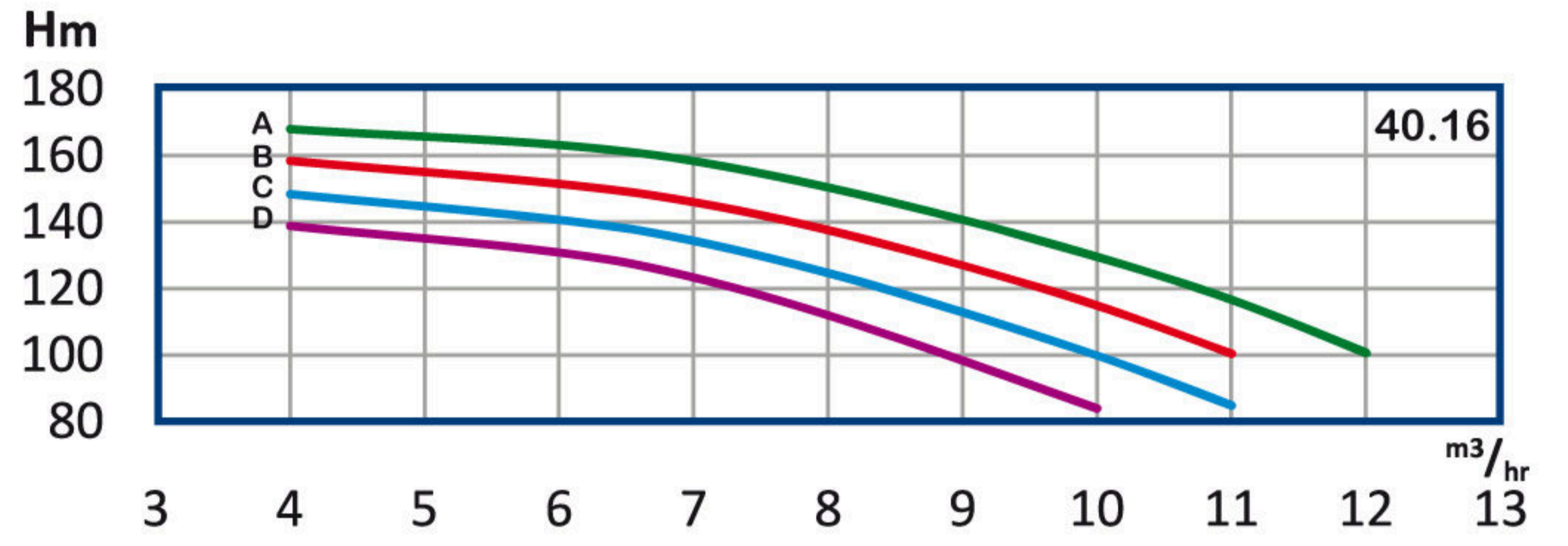
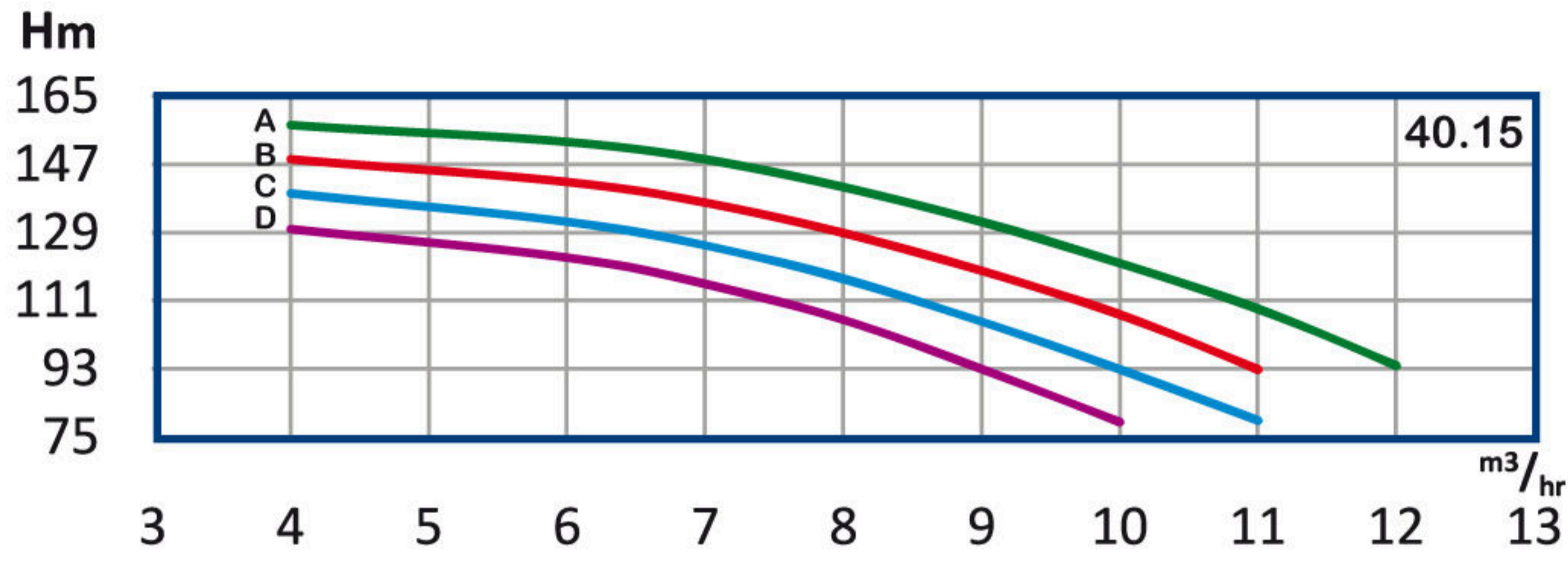
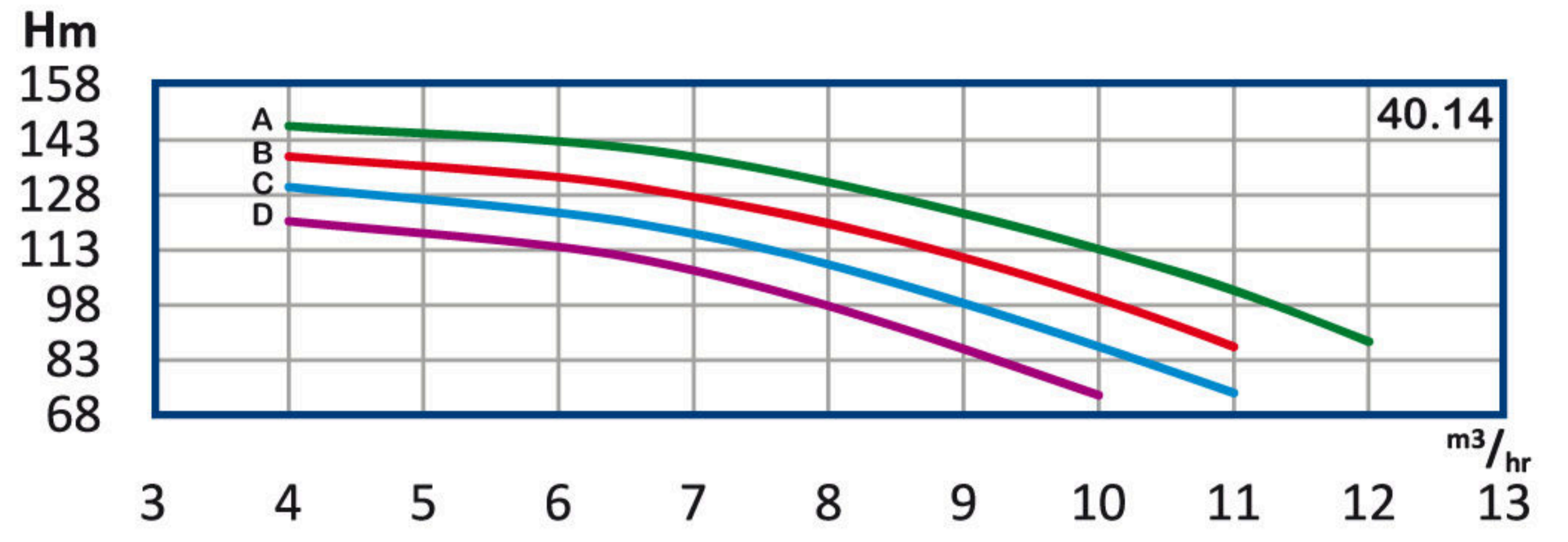
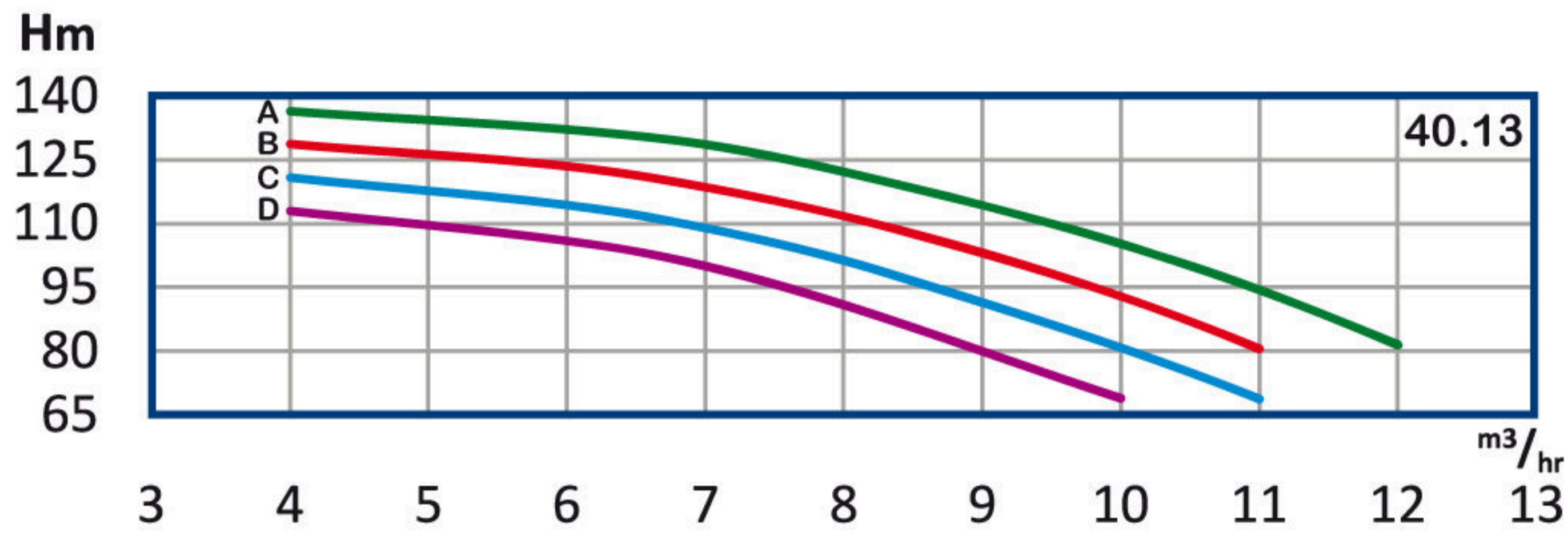

جدول طول پمپ WKL4 40 (mm)

| تعداد طبقه | B | E | تعداد طبقه | B | E |
|------------|-----|-----|------------|-----|-----|
| 1 | 82 | 202 | 10 | 514 | 634 |
| 2 | 130 | 250 | 11 | 562 | 682 |
| 3 | 178 | 298 | 12 | 610 | 730 |
| 4 | 226 | 346 | 13 | 658 | 778 |
| 5 | 274 | 394 | 14 | 706 | 826 |
| 6 | 322 | 442 | 15 | 754 | 874 |
| 7 | 370 | 490 | 16 | 802 | 922 |
| 8 | 418 | 538 | 17 | 850 | 970 |
| 9 | 466 | 586 | | | |

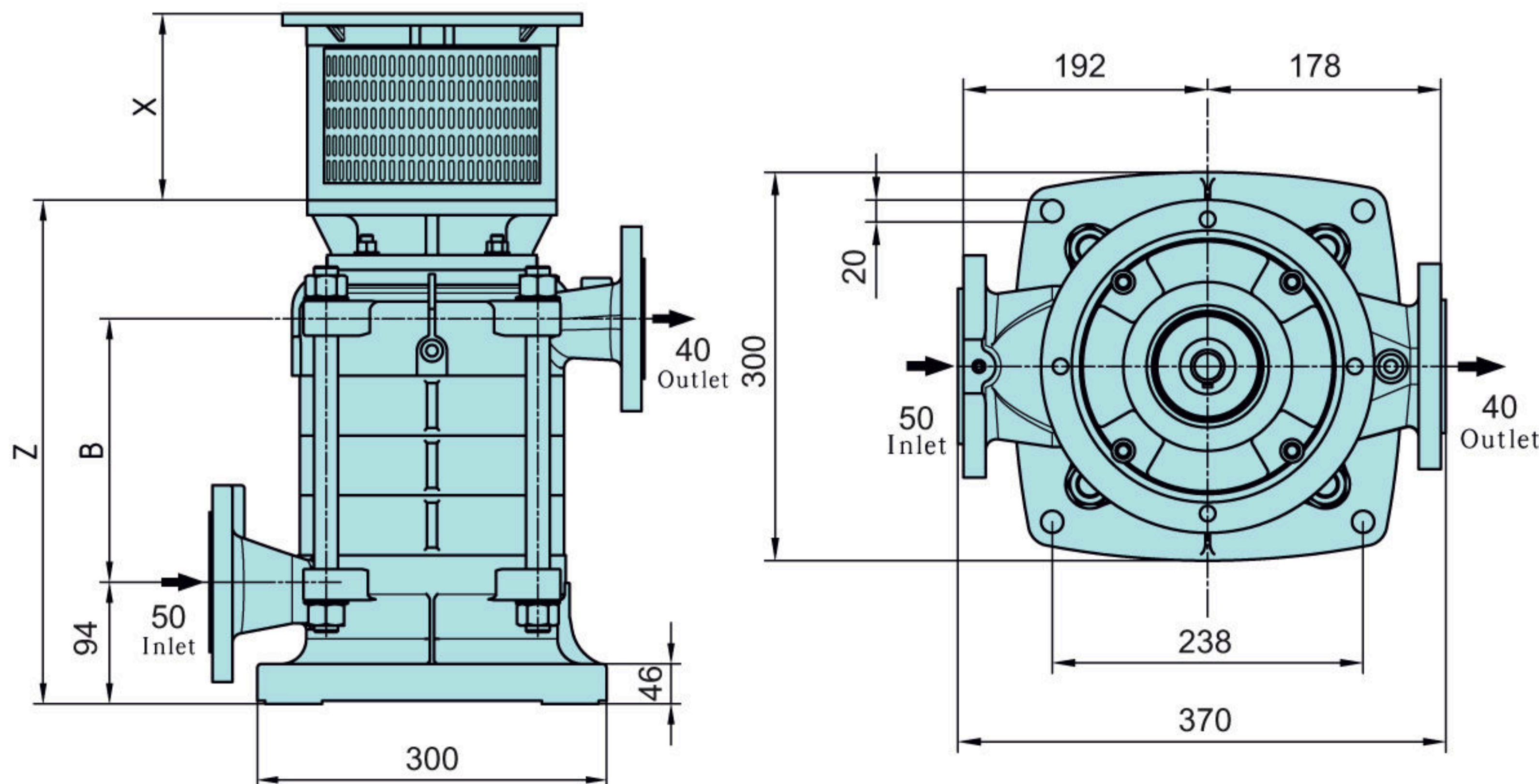

جدول طول پمپ WKL4 40 (mm)

| تعداد طبقه | B | Z | تعداد طبقه | B | Z |
|------------|-----|-----|------------|-----|------|
| 1 | 89 | 294 | 9 | 473 | 678 |
| 2 | 137 | 342 | 10 | 521 | 726 |
| 3 | 185 | 390 | 11 | 569 | 774 |
| 4 | 233 | 438 | 12 | 617 | 822 |
| 5 | 281 | 486 | 13 | 665 | 870 |
| 6 | 329 | 534 | 14 | 713 | 918 |
| 7 | 377 | 582 | 15 | 761 | 966 |
| 8 | 425 | 630 | 16 | 809 | 1014 |

X: متناسب با قدرت الکترو موتور تغییر می یابد.

n≈ 2900 rpm

پمپ WKL 40 , WKL V

| تیپ پمپ | توان P | | آمپر A | قطر پروانه D (mm) | قطر فلنج mm | | Q آبدھی | | | | | | | | |
|--------------|--------|-----|--------|-------------------|-------------|------|---------|-------|------|------|------|------|------|------|------|
| | KW | HP | | | مکش | رانس | m3/h | H (m) | | | | | | | |
| | | | | | | | | 2.22 | 3.33 | 3.9 | 4.45 | 5 | 5.56 | 6.11 | 6.67 |
| WKL V 40.1 D | 3 | 4 | 6 | 155 | 50 | 40 | H (m) | 34.3 | 31.8 | 30 | 27.5 | 24.2 | 21 | * | * |
| WKL V 40.1 C | 4 | 5.5 | 8 | 160 | | | | 36.7 | 34.6 | 33 | 30.7 | 28 | 25 | 21.5 | * |
| WKL V 40.1 B | 4 | 5.5 | 8 | 165 | | | | 39.2 | 37.5 | 36 | 34.2 | 31.8 | 29 | 25.5 | * |
| WKL V 40.1 A | 4 | 5.5 | 8 | 170 | | | | 41.5 | 40 | 38.7 | 37 | 34.8 | 32.3 | 29.5 | 26 |
| WKL V 40.2 D | 7.5 | 10 | 15 | 155 | | | | 67 | 63.5 | 60 | 55 | 48.5 | 42 | * | * |
| WKL V 40.2 C | 7.5 | 10 | 15 | 160 | | | | 72.5 | 69.5 | 66 | 61.2 | 55.4 | 49.2 | 43 | * |
| WKL V 40.2 B | 7.5 | 10 | 15 | 165 | | | | 78 | 75.5 | 73 | 69 | 63.8 | 58 | 51.2 | * |
| WKL V 40.2 A | 11 | 15 | 22.5 | 170 | | | | 83.5 | 81 | 78.5 | 75.5 | 71 | 65.8 | 59 | 52 |
| WKL V 40.3 D | 11 | 15 | 22.5 | 155 | | | | 101 | 95.5 | 90 | 82.5 | 72.7 | 63 | * | * |
| WKL V 40.3 C | 11 | 15 | 22.5 | 160 | | | | 109 | 104 | 99.5 | 92 | 83.5 | 73.5 | * | * |
| WKL V 40.3 B | 11 | 15 | 22.5 | 165 | | | | 118 | 113 | 109 | 103 | 96 | 87 | 76.5 | * |
| WKL V 40.3 A | 15 | 20 | 30 | 170 | | | | 126 | 122 | 118 | 113 | 106 | 98.5 | 89 | 78 |
| WKL V 40.4 D | 15 | 20 | 30 | 155 | | | | 138 | 128 | 120 | 110 | 97 | 84 | * | * |
| WKL V 40.4 C | 15 | 20 | 30 | 160 | | | | 148 | 140 | 132 | 122 | 110 | 98 | 86 | * |
| WKL V 40.4 B | 15 | 20 | 30 | 165 | | | | 158 | 151 | 145 | 136 | 126 | 115 | 102 | * |
| WKL V 40.4 A | 18.5 | 25 | 36 | 170 | | | | 168 | 163 | 157 | 150 | 141 | 130 | 118 | 104 |
| WKL V 40.5 D | 15 | 20 | 30 | 155 | | | | 170 | 161 | 151 | 138 | 122 | 105 | * | * |
| WKL V 40.5 C | 18.5 | 25 | 36 | 160 | | | | 183 | 175 | 166 | 154 | 139 | 124 | 108 | * |
| WKL V 40.5 B | 18.5 | 25 | 36 | 165 | | | | 196 | 189 | 181 | 170 | 157 | 142 | 126 | * |
| WKL V 40.5 A | 22 | 30 | 42.5 | 170 | | | | 210 | 204 | 197 | 188 | 176 | 163 | 148 | 131 |
| WKL V 40.6 D | 18.5 | 25 | 36 | 155 | | | | 204 | 192 | 181 | 165 | 146 | 126 | * | * |
| WKL V 40.6 C | 22 | 30 | 42.5 | 160 | | | | 222 | 210 | 198 | 184 | 167 | 148 | 129 | * |
| WKL V 40.6 B | 22 | 30 | 42.5 | 165 | | | | 237 | 228 | 218 | 205 | 190 | 173 | 153 | * |
| WKL V 40.6 A | 22 | 30 | 42.5 | 170 | | | | 252 | 244 | 236 | 225 | 211 | 195 | 177 | 157 |

| H | m | 21 | 46 | 67 | 88 | 110 | 131 | 152 | 174 | 195 | 216 | 238 | 260 |
|---|----|----|-----|-----|-----|-----|-----|-----|-----|-----|-----|-----|-----|
| | ft | 70 | 150 | 220 | 290 | 360 | 430 | 500 | 570 | 640 | 710 | 780 | 850 |

| Q | m3 /h | 8 | 12 | 14 | 16 | 18 | 20 | 22 | 24 |
|---|-------|----|----|----|----|----|----|----|----|
| | g.p.m | 30 | 45 | 53 | 61 | 68 | 76 | 83 | 91 |

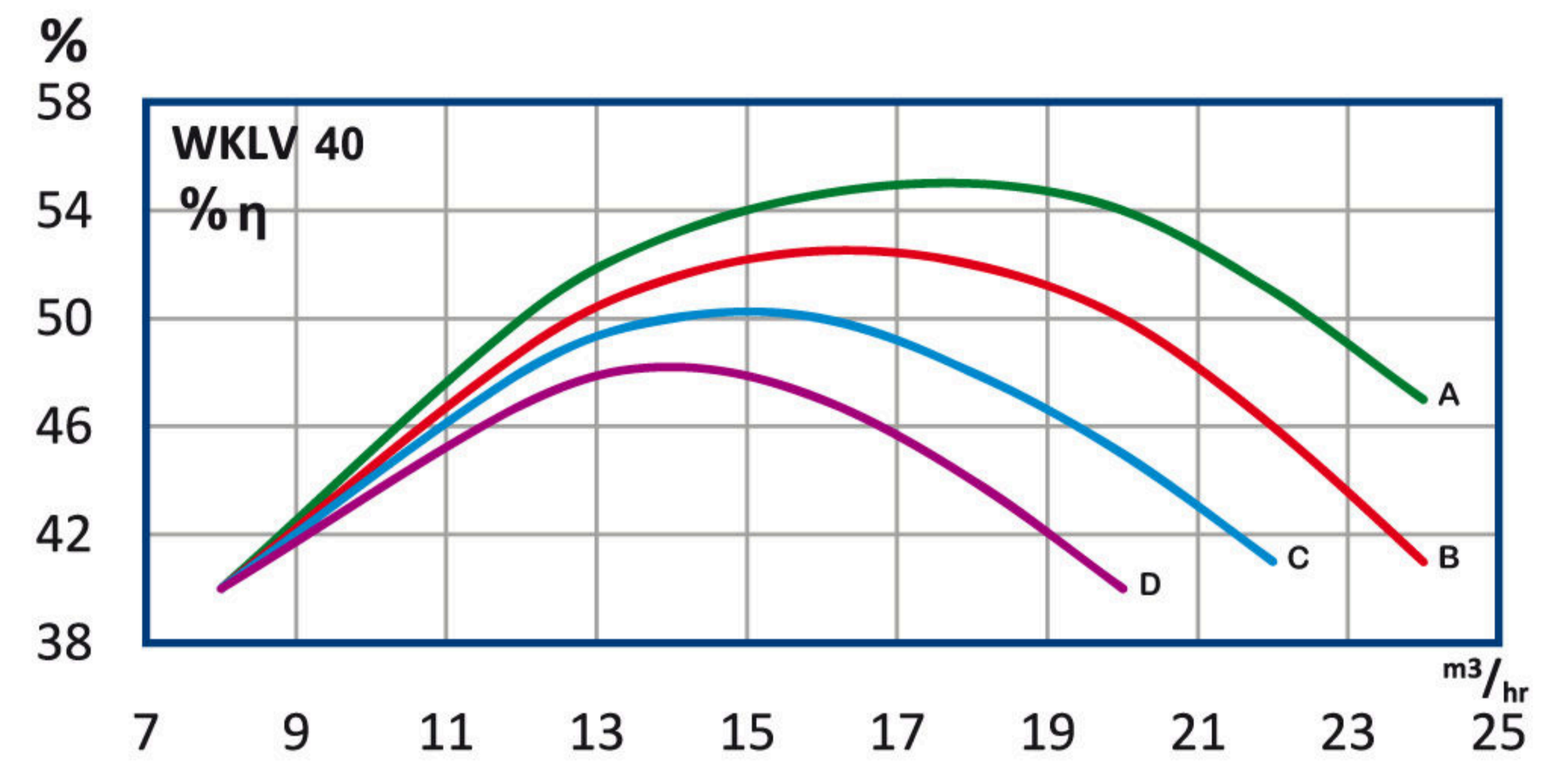
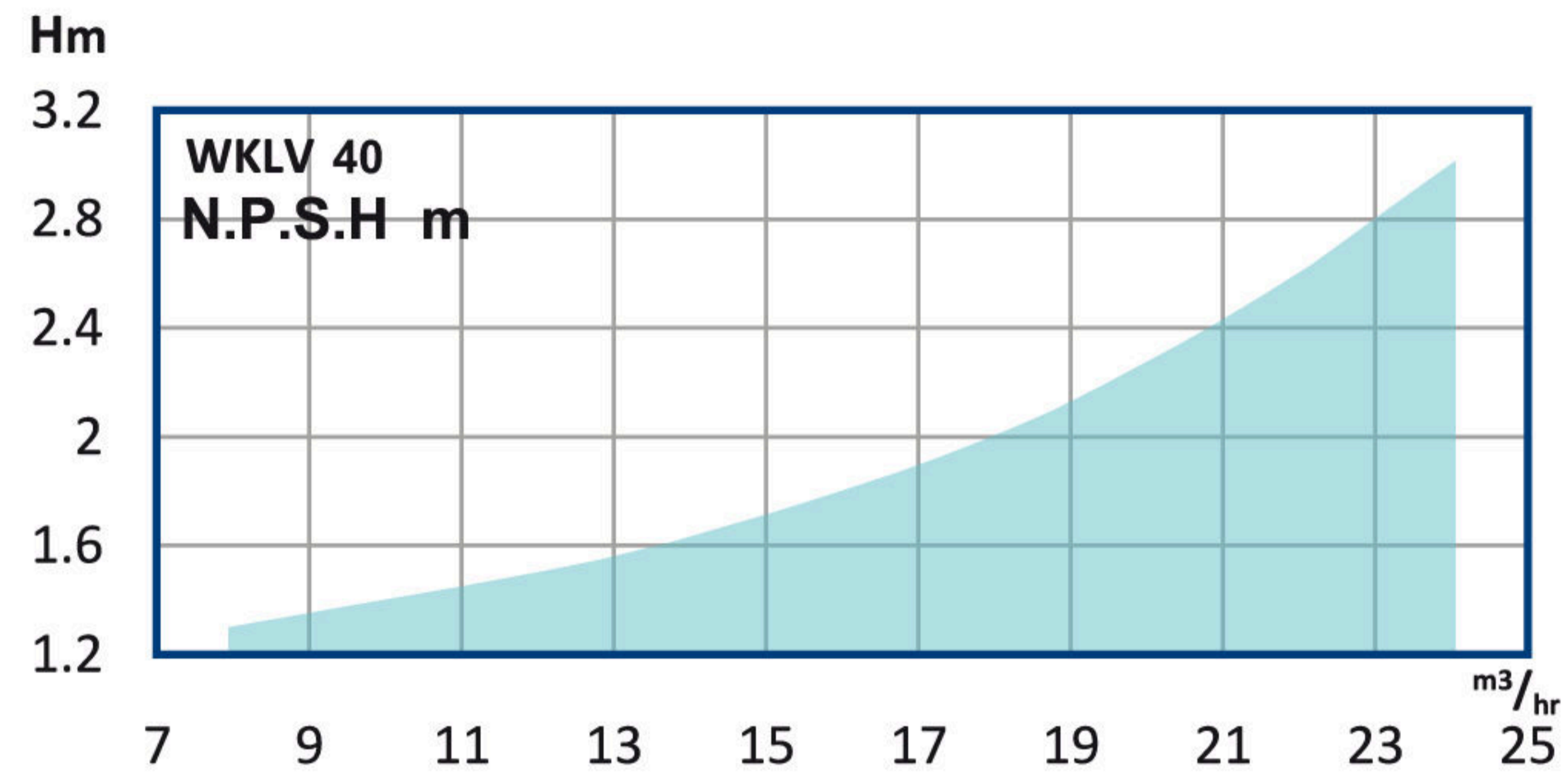
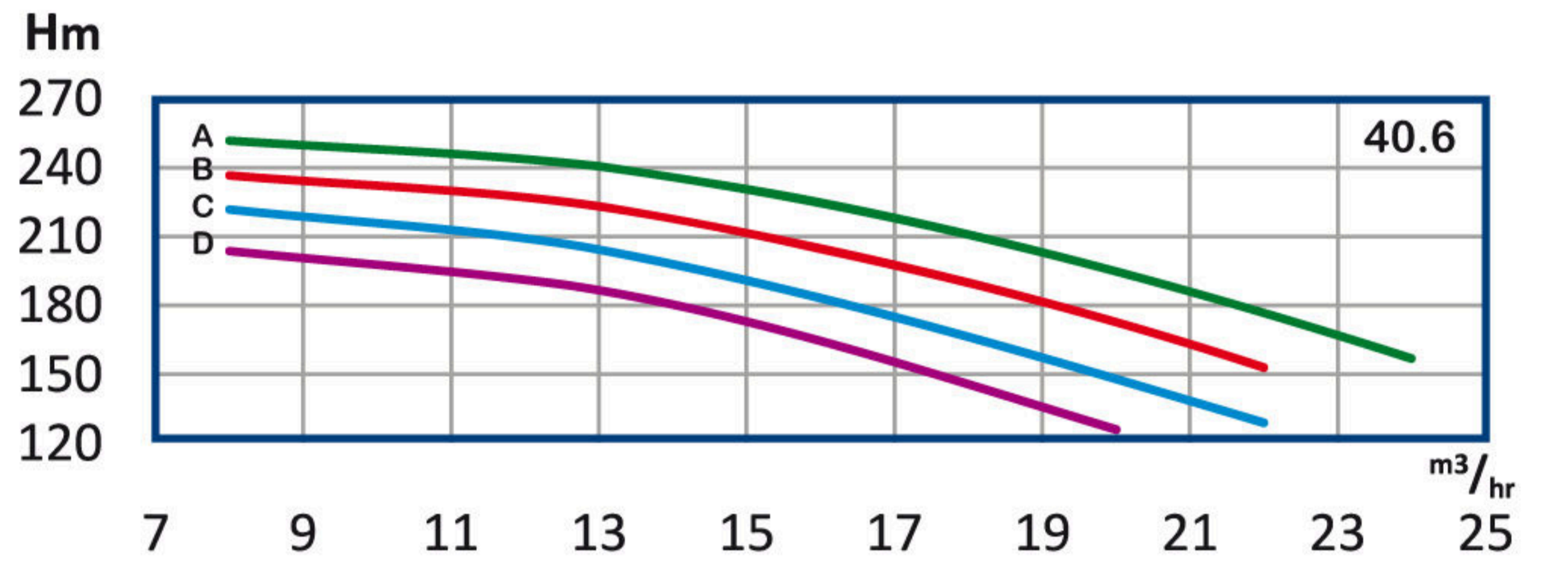
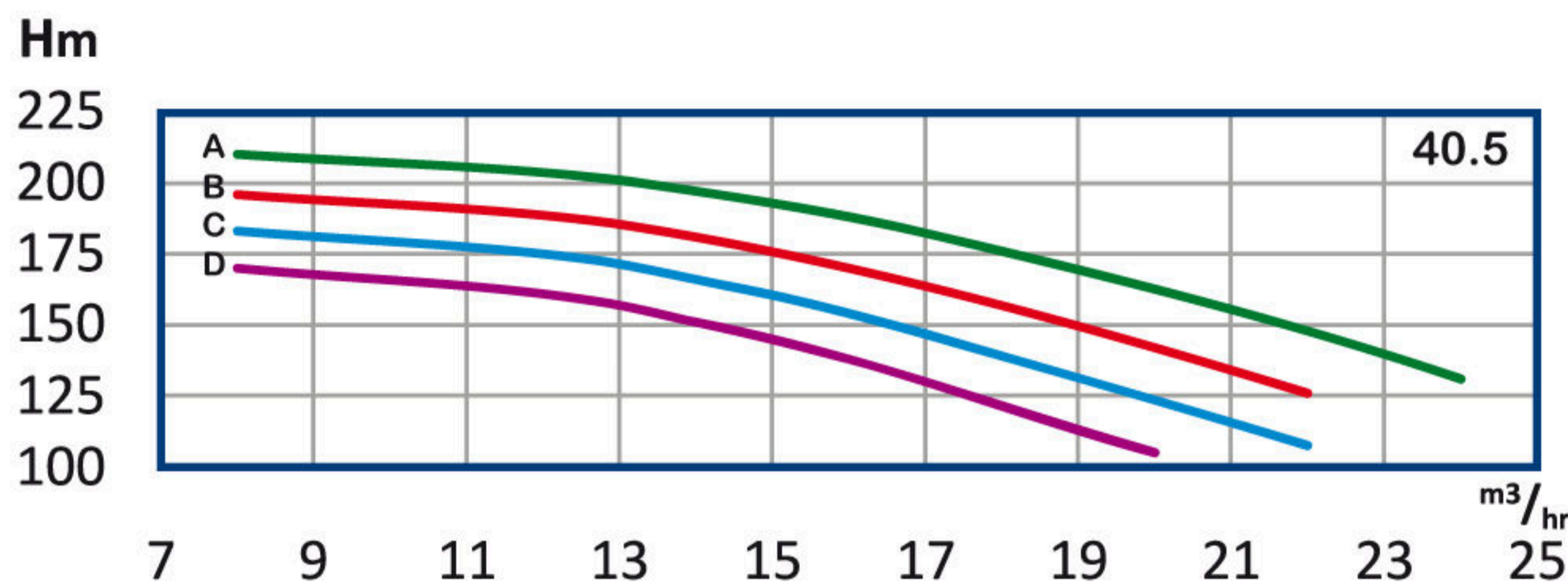
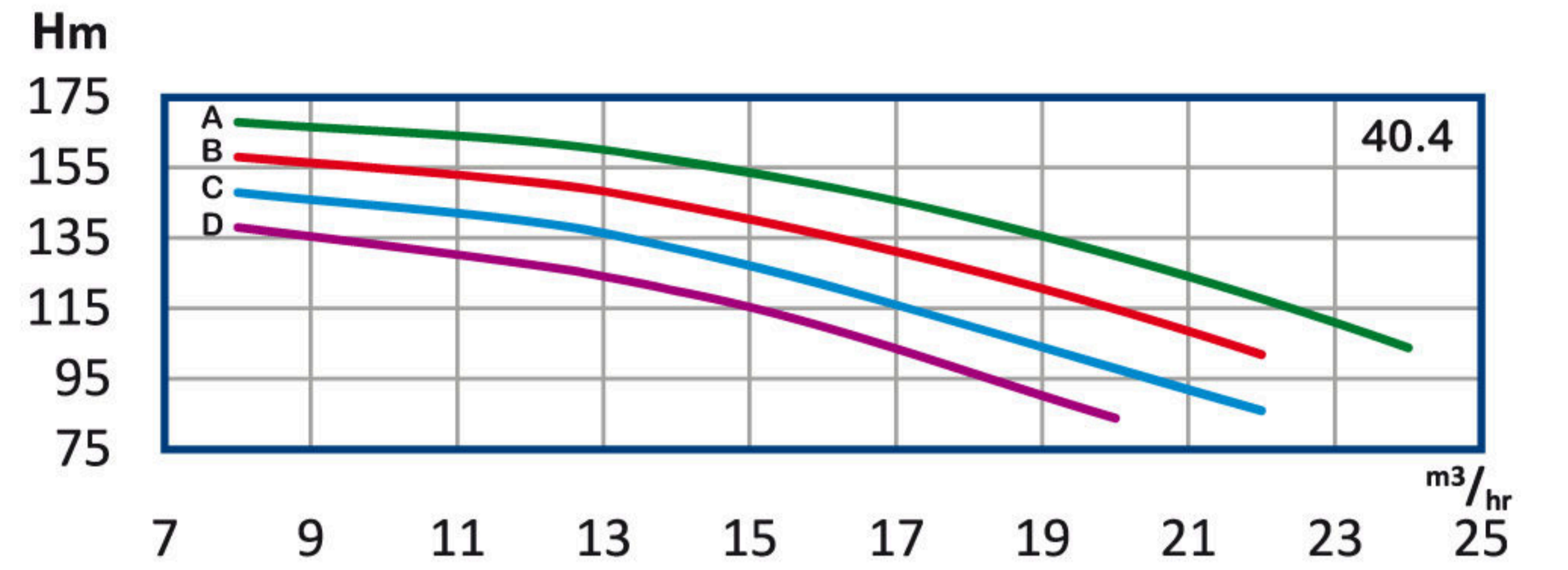
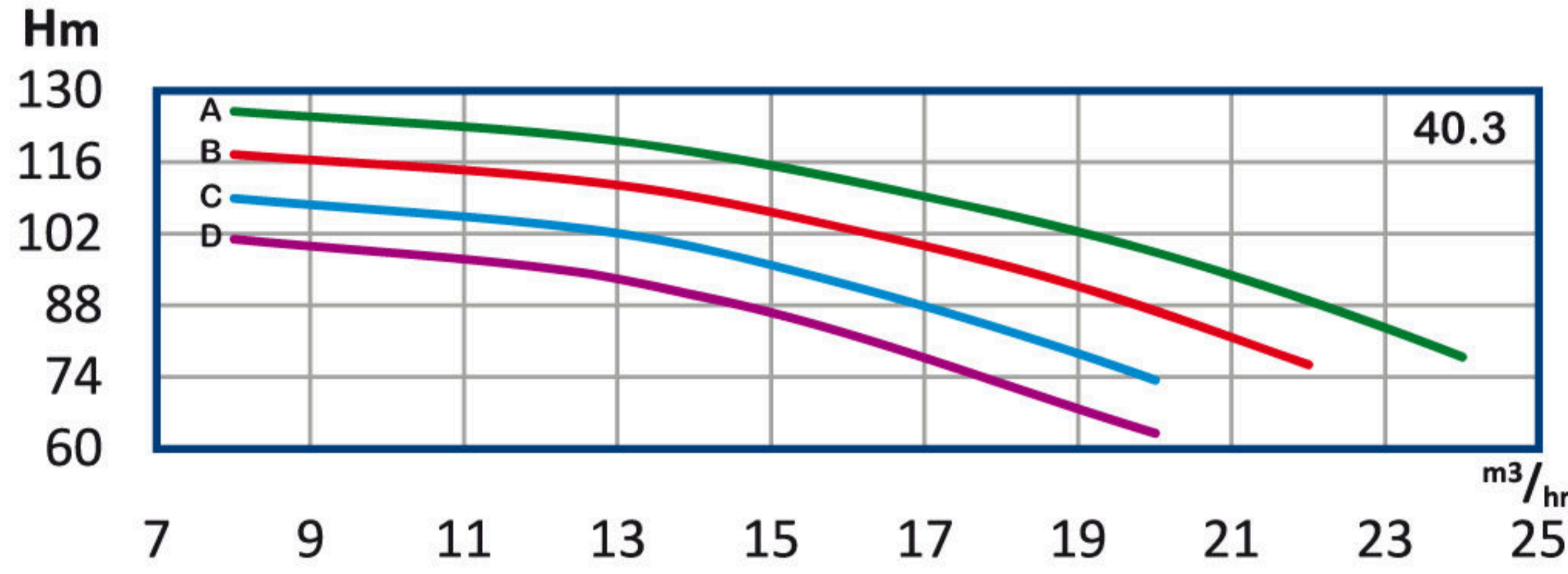
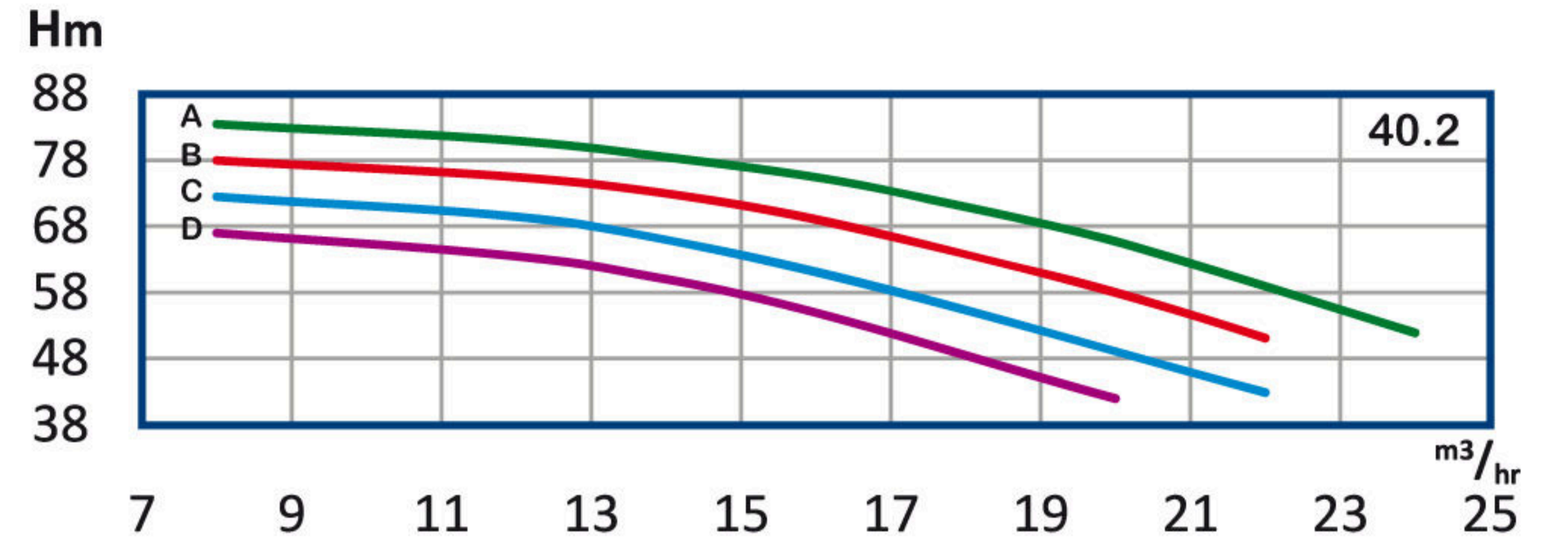
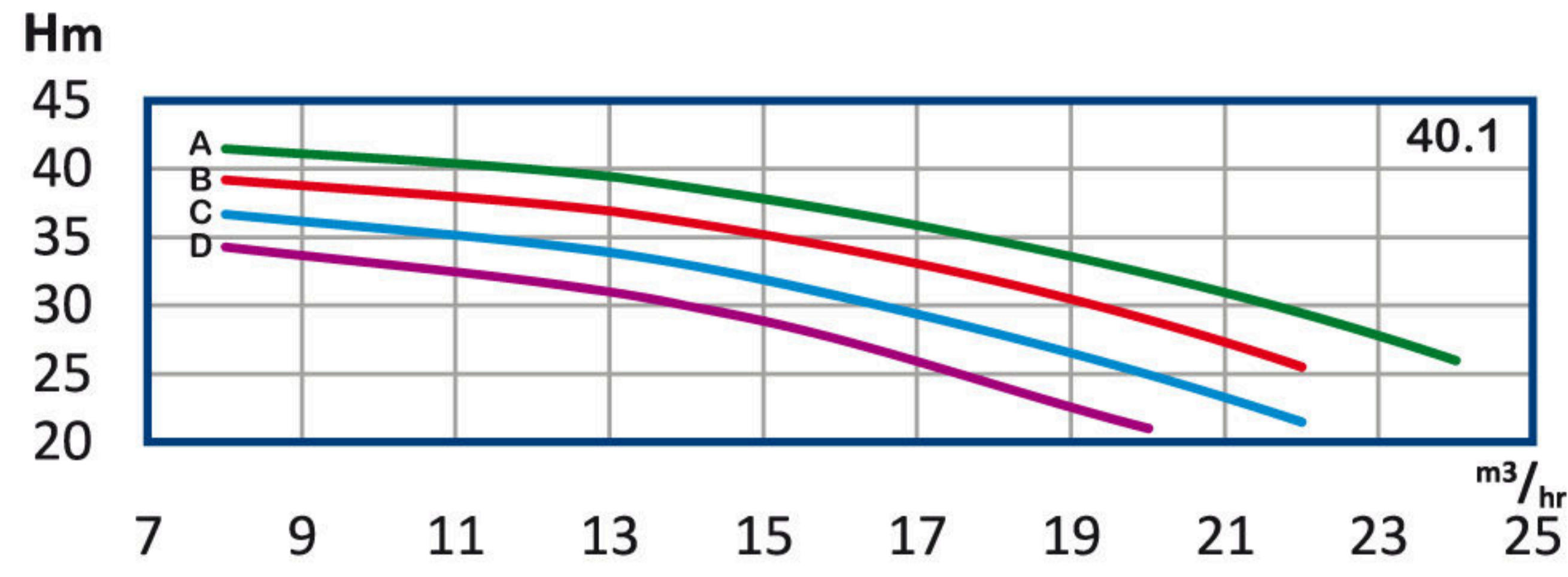

n≈ 2900 rpm

پمپ 40 WKL, WKL

| تیپ پمپ | توان P | | آمپر A | قطر پروانه D (mm) | قطر فلنج mm | | Q آبدھی | | | | | | | | |
|------------|--------|----|--------|-------------------|-------------|------|---------|-------------------|-----|------|-----|------|------|------|-----|
| | KW | HP | | | مکش | رانس | H (m) | m ³ /h | 8 | 12 | 14 | 16 | 18 | 20 | 22 |
| | | | l/s | 2.22 | | | | 3.33 | 3.9 | 4.45 | 5 | 5.56 | 6.11 | 6.67 | |
| WKL 40.7 D | 22 | 30 | 42.5 | 155 | 50 | 40 | H (m) | 238 | 224 | 211 | 193 | 171 | 147 | * | * |
| WKL 40.7 C | 22 | 30 | 42.5 | 160 | | | | 257 | 244 | 232 | 215 | 195 | 174 | 151 | * |
| WKL 40.7 B | 30 | 40 | 57 | 165 | | | | 276 | 266 | 256 | 241 | 223 | 203 | 179 | * |
| WKL 40.7 A | 30 | 40 | 57 | 170 | | | | 294 | 285 | 276 | 263 | 246 | 228 | 207 | 183 |
| WKL 40.8 D | 30 | 40 | 57 | 155 | | | | 272 | 256 | 240 | 220 | 194 | 168 | * | * |
| WKL 40.8 C | 30 | 40 | 57 | 160 | | | | 292 | 279 | 265 | 245 | 222 | 198 | 172 | * |
| WKL 40.8 B | 30 | 40 | 57 | 165 | | | | 314 | 302 | 290 | 272 | 252 | 229 | 204 | * |
| WKL 40.8 A | 30 | 40 | 57 | 170 | | | | 333 | 321 | 310 | 295 | 277 | 257 | 235 | 208 |

| H | m | 146 | 162 | 177 | 192 | 207 | 226 | 244 | 262 | 280 | 299 | 317 | 335 |
|---|----|-----|-----|-----|-----|-----|-----|-----|-----|-----|-----|------|------|
| | ft | 480 | 530 | 580 | 630 | 680 | 740 | 800 | 860 | 920 | 980 | 1040 | 1100 |

| Q | m ³ /h | 8 | 12 | 14 | 16 | 18 | 20 | 22 | 24 |
|---|-------------------|----|----|----|----|----|----|----|----|
| | g.p.m | 30 | 45 | 53 | 61 | 68 | 76 | 83 | 91 |

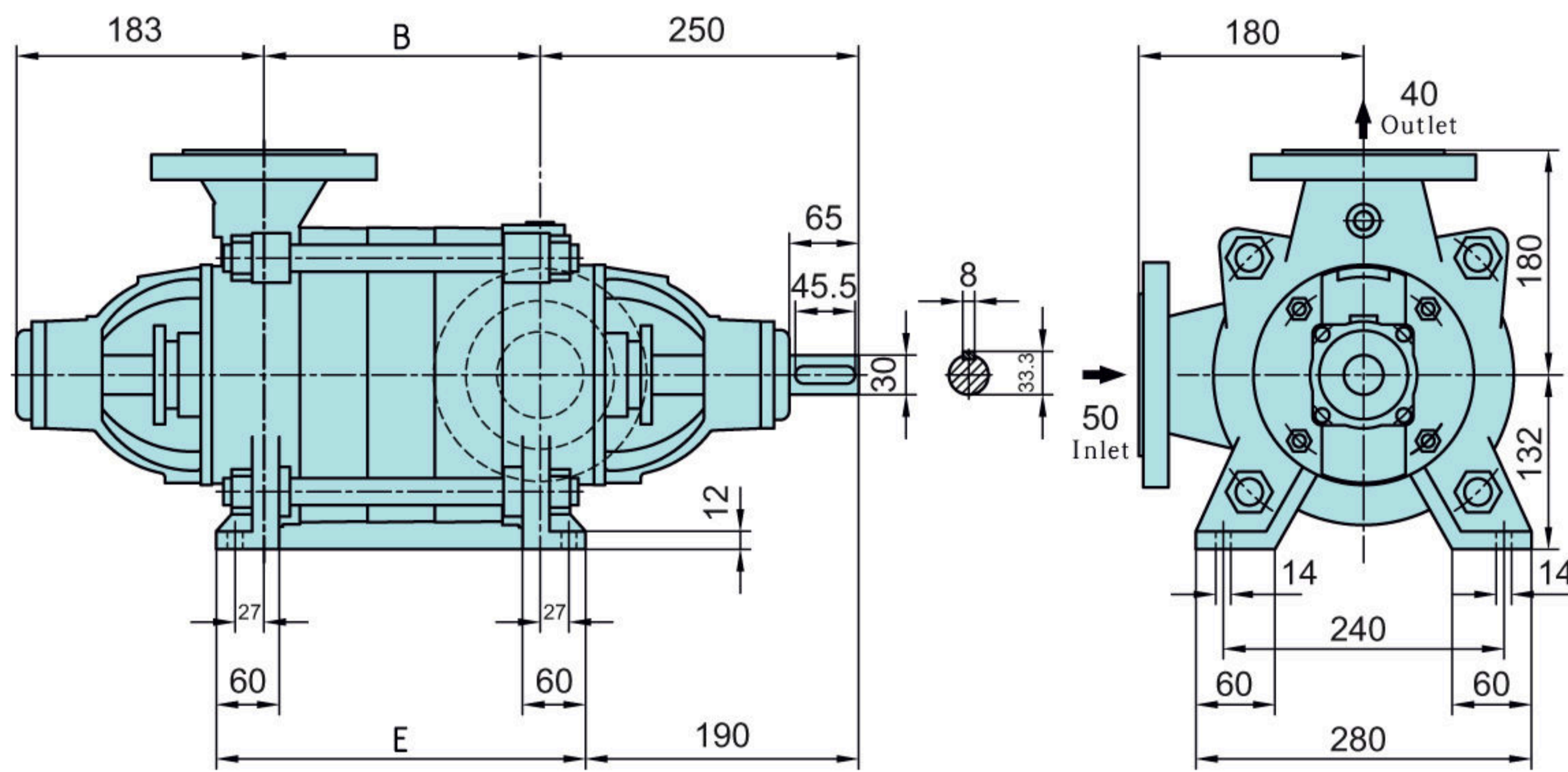
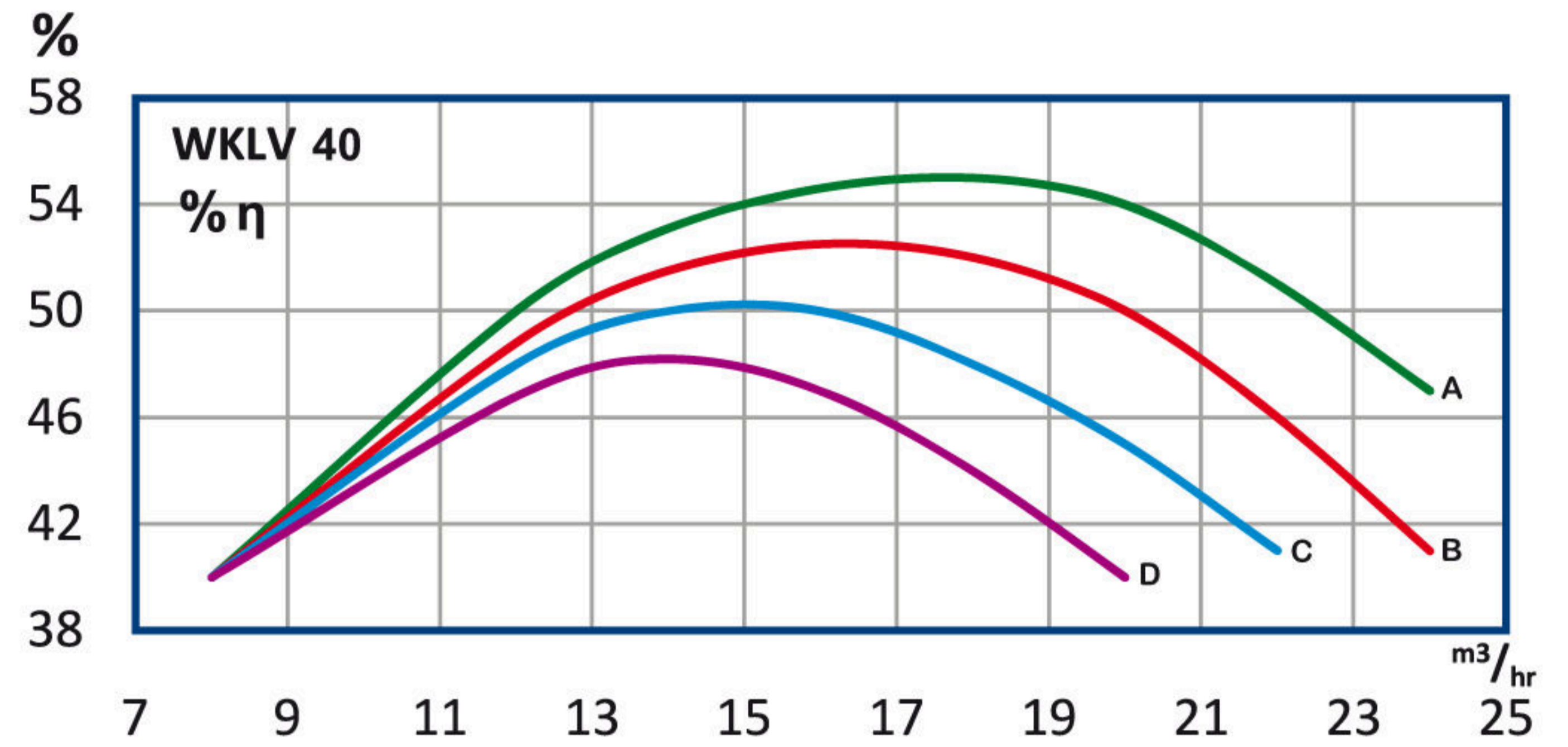
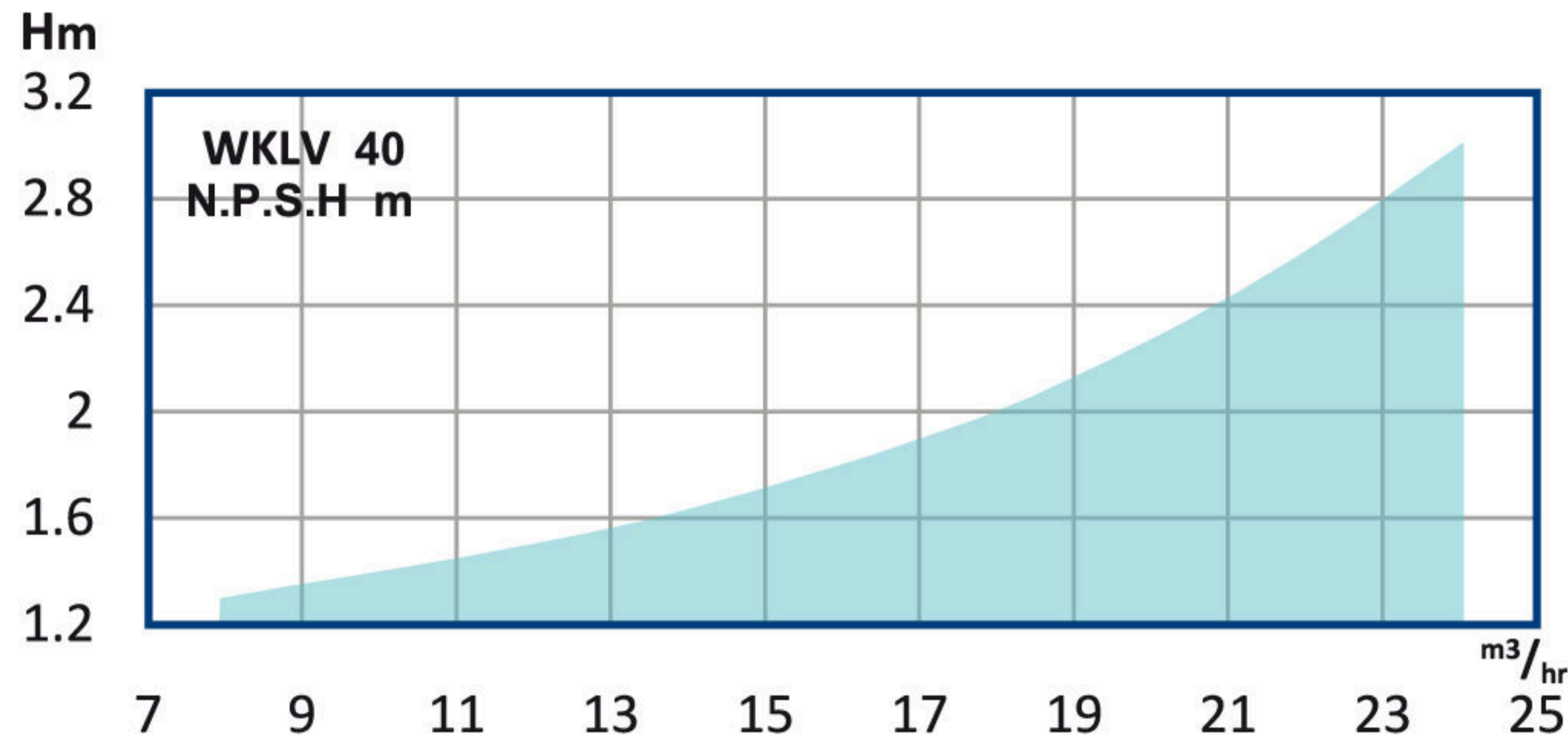
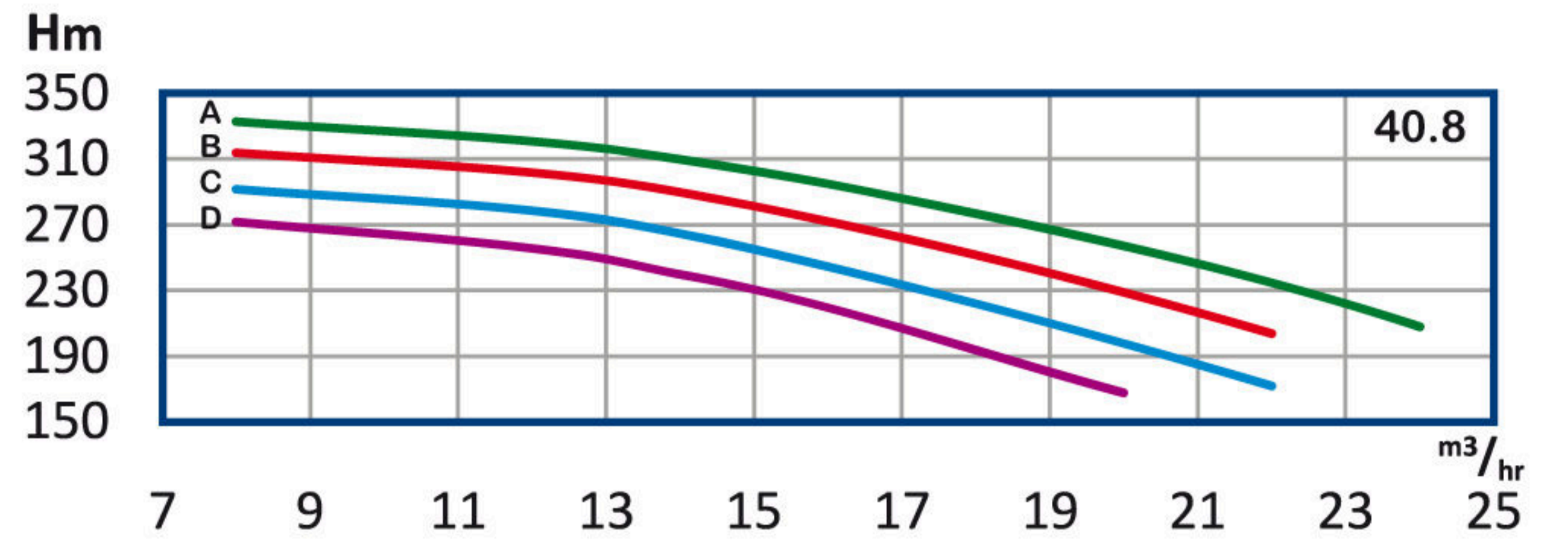
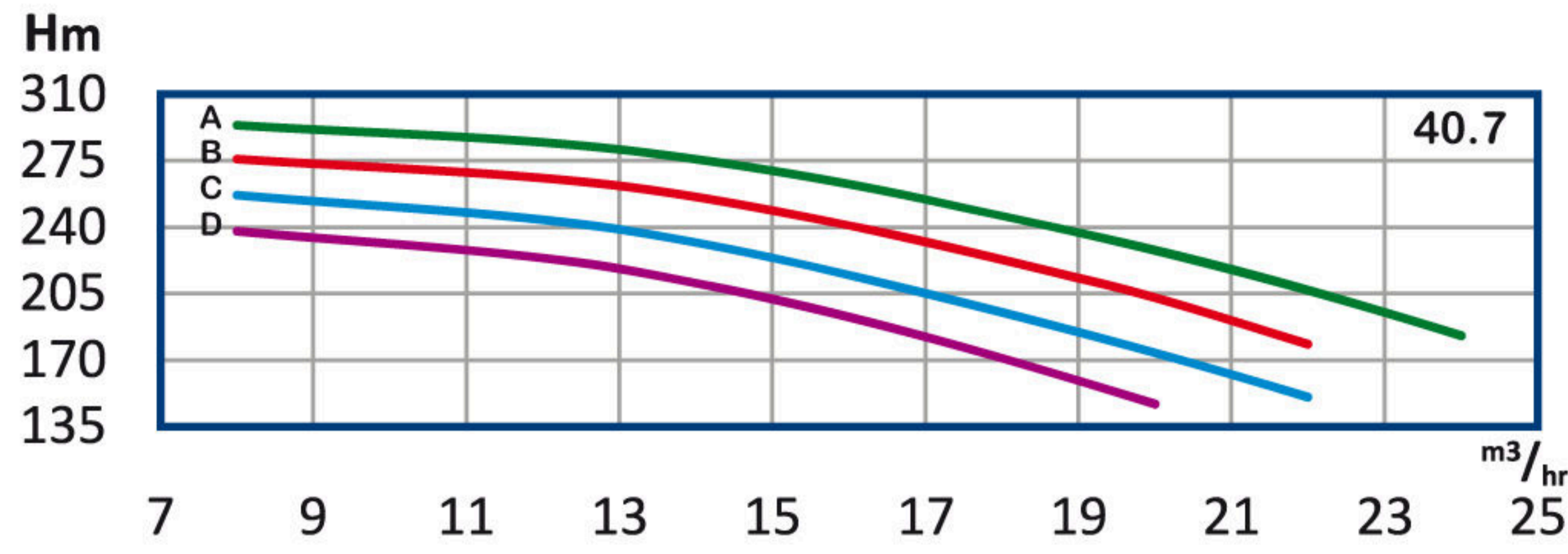

جدول طول پمپ (mm) WKL 40

| تعداد طبقه | B | E | تعداد طبقه | B | E |
|------------|-----|-----|------------|-----|-----|
| 1 | 82 | 202 | 5 | 274 | 394 |
| 2 | 130 | 250 | 6 | 322 | 442 |
| 3 | 178 | 298 | 7 | 370 | 490 |
| 4 | 226 | 346 | 8 | 418 | 538 |

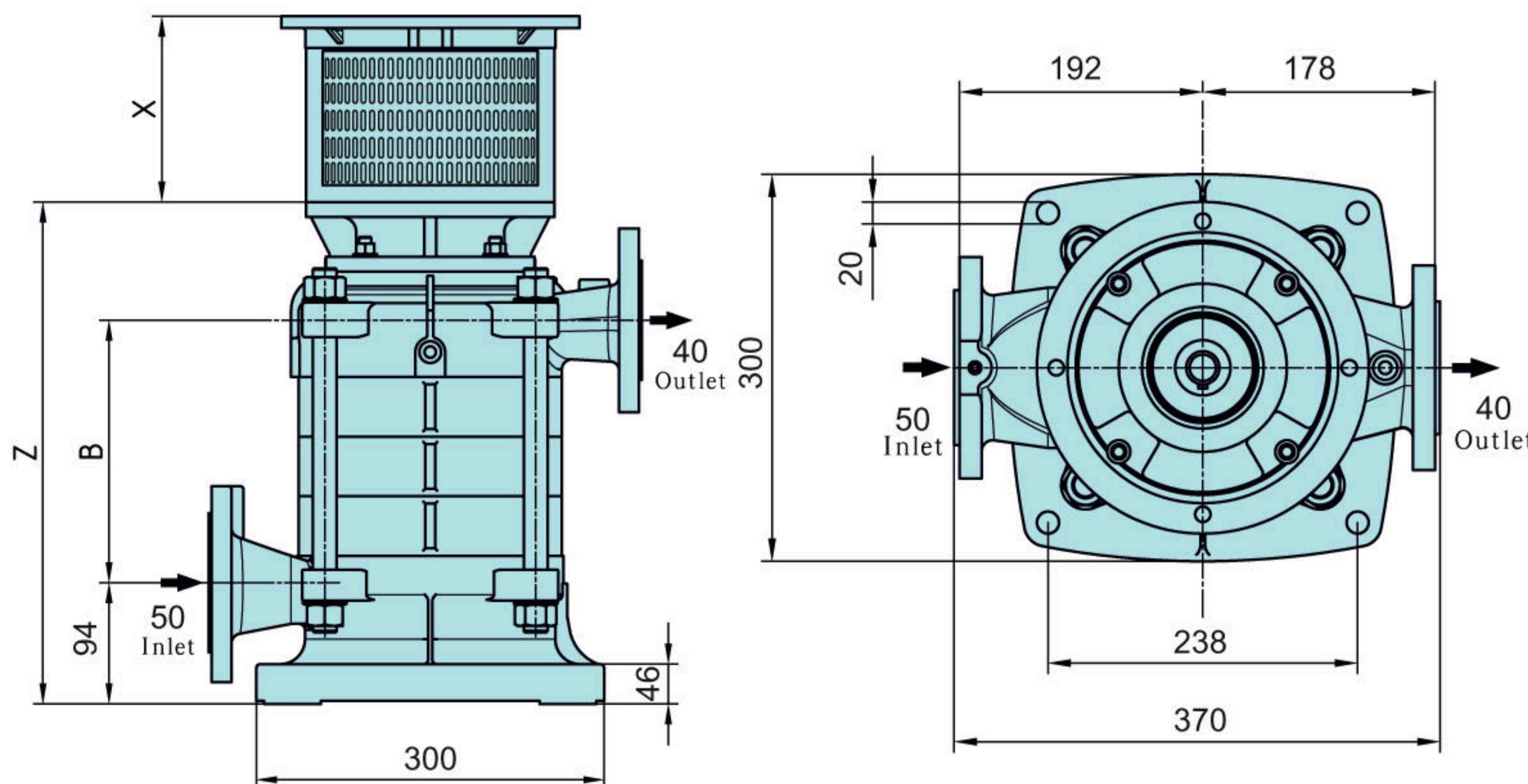

جدول طول پمپ (mm) WKL 40

| تعداد طبقه | B | Z | تعداد طبقه | B | Z |
|------------|-----|-----|------------|-----|-----|
| 1 | 89 | 294 | 5 | 281 | 486 |
| 2 | 137 | 342 | 6 | 329 | 534 |
| 3 | 185 | 390 | 7 | 377 | 582 |
| 4 | 233 | 438 | 8 | 425 | 630 |

X: متناسب با قدرت الکترو موتور تغییر می یابد.

جدول ابعاد پمپ های WKL4 , WKL (32-65)

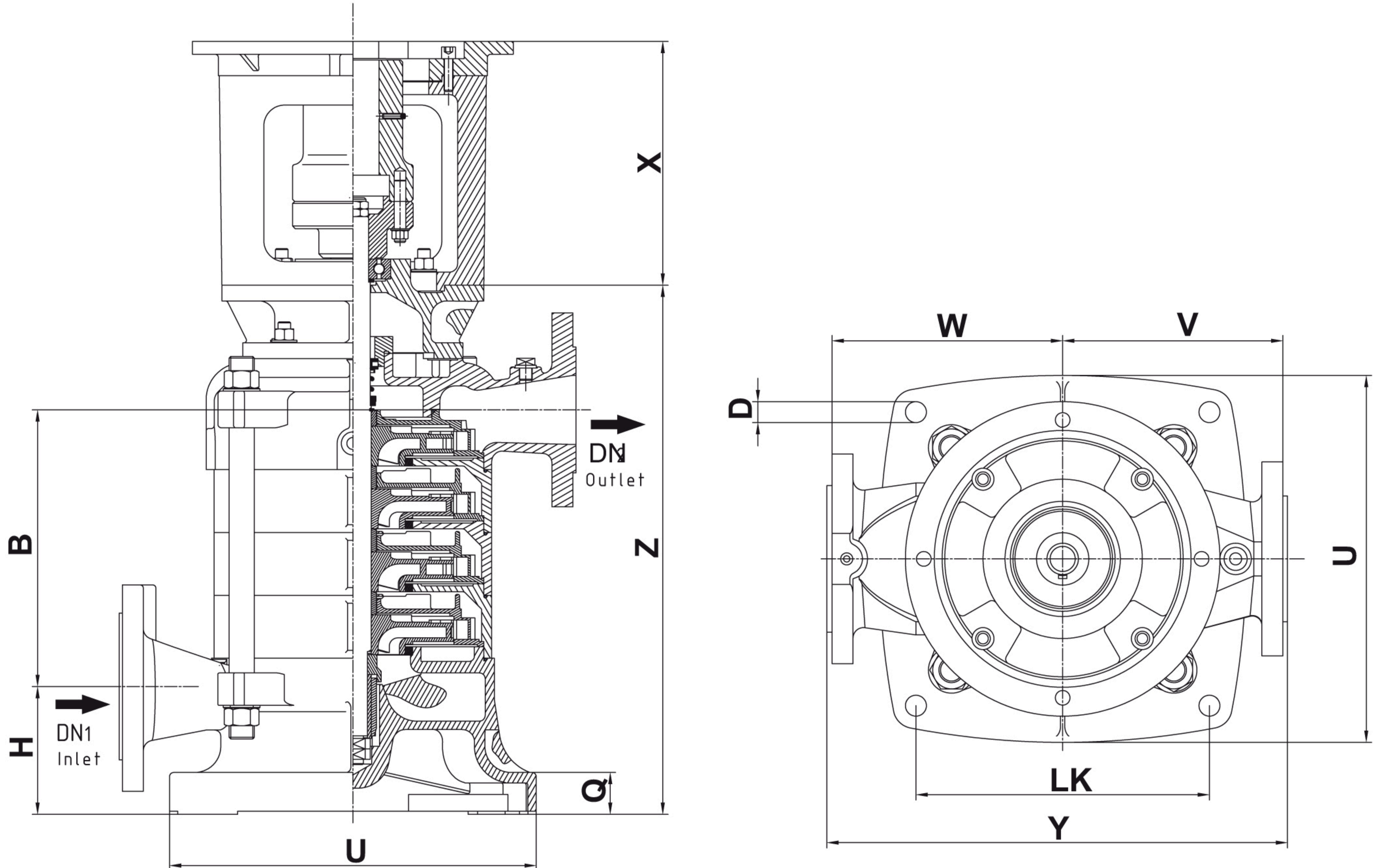

| Type | (mm) | | | | | | | | | |
|------------------|------|-----|-----|-----|-----|----|-----|-----|----|-----|
| | DN1 | DN2 | LK | Y | U | D | W | V | Q | H |
| WKL4 / WKL 32 | 40 | 32 | 216 | 349 | 280 | 20 | 180 | 163 | 40 | 92 |
| WKL4 / WKL 40 | 50 | 40 | 238 | 370 | 300 | 20 | 192 | 178 | 46 | 94 |
| WKL4 / WKL 50 | 65 | 50 | 250 | 392 | 330 | 20 | 206 | 180 | 38 | 103 |
| WKL4 / WKL 65 | 80 | 65 | 280 | 430 | 350 | 20 | 220 | 210 | 40 | 122 |

| Type | طول پمپ | (mm) | | | | | | | | | | | | | | | | |
|------------------|---------|------|-----|-----|-----|-----|-----|-----|-----|-----|-----|-----|-----|-----|------|-----|------|------|
| | | 1 | 2 | 3 | 4 | 5 | 6 | 7 | 8 | 9 | 10 | 11 | 12 | 13 | 14 | 15 | 16 | 17 |
| WKL4 / WKL 32 | B | 76 | 124 | 172 | 220 | 268 | 316 | 364 | 412 | 460 | 508 | 556 | 604 | 652 | 700 | 748 | 796 | 844 |
| | Z | 279 | 327 | 375 | 423 | 471 | 519 | 567 | 615 | 663 | 711 | 759 | 807 | 855 | 903 | 951 | 999 | 1047 |
| WKL4 / WKL 40 | B | 89 | 137 | 185 | 233 | 281 | 329 | 377 | 425 | 473 | 521 | 569 | 617 | 665 | 713 | 761 | 809 | * |
| | Z | 294 | 342 | 390 | 438 | 486 | 534 | 582 | 630 | 678 | 726 | 774 | 822 | 870 | 918 | 966 | 1014 | * |
| WKL4 / WKL 50 | B | 82 | 137 | 192 | 247 | 302 | 357 | 412 | 467 | 522 | 577 | 632 | 687 | 742 | 797 | * | * | * |
| | Z | 310 | 365 | 420 | 475 | 530 | 585 | 640 | 695 | 750 | 805 | 860 | 915 | 970 | 1025 | * | * | * |
| WKL4 / WKL 65 | B | 84 | 144 | 204 | 264 | 324 | 384 | 444 | 504 | 564 | 624 | 684 | 747 | * | * | * | * | * |
| | Z | 325 | 385 | 445 | 505 | 565 | 625 | 685 | 745 | 805 | 865 | 925 | 985 | * | * | * | * | * |